



AccessPoint™

Mobile Computing

Mobile Computing System Operator Manual



Document Number L01-530
Revision E

TouchPoint Medical
114 Douglas Road East
Oldsmar, FL 34677 USA
www.touchpointmed.com
800-947-3901

TouchPoint Medical Customer Service: For all customer service related issues, or if you need technical assistance, call our customer service department.

1-800-947-3901	Americas
877-671-3162	International
800-852-627	Australia
855-894-2710	Mexico

TouchPoint Medical reserves the right to make improvements or changes in the products described in this manual at any time without notice.

While reasonable efforts have been made in the preparation of this document to assure its accuracy, TouchPoint Medical assumes no liability resulting from any errors or omissions in this document, or from the use of the information contained herein.

© 2016 TouchPoint Medical. All rights reserved.

TouchPoint Medical logo is a trademark of TouchPoint Medical.

TouchPoint Medical is a division of TouchPoint, Inc.

This manual is copyrighted. All rights reserved. This manual may be printed for personal use only. This manual, whole or in part, may not be copied, photocopied, reproduced, translated, or reduced to any electronic medium or machine-readable form for distribution. This manual, whole or in part, may not be modified without prior consent, in writing, from TouchPoint Medical.

Contents

1

Introduction to TouchPoint Medical AccessPoint

Workstations	1-1
Introduction	1-2
AccessPoint Product Configurations	1-3
Equipment Classification	1-4
Important Product Notices	1-4
Important Safety Instructions for Installers	1-4
Disposal	1-5
Intended Use	1-6
Chapter Content	1-6
Illustrations	1-6
Safety Information	1-8
Regulatory Compliance	1-8
Important Safety Instructions	1-8
Notes	1-9
FCC Information	1-9
Industry Canada	1-10
Safety Labels	1-10
Revision History	1-11
Reference Documents	1-12

2

Getting Started 2-1

Getting Started with the Workstation	2-2
Unpacking	2-2
Inspection	2-2
Shipment of Power Supply	2-2
Connect the Power Supply Batteries	2-3
Charge Power Supply Battery	2-6
Integration	2-8
Computer Power Tips and Cable Connections	2-8
Configure Selectable Voltages	2-10
Remove Work Surface	2-12
Technology Tray	2-13
Route Monitor Cables	2-20
Setup Keyboard and Mouse	2-22
Install Work Surface	2-24

Wake on LAN / Wake on Power	2-25
Wake on LAN	2-25
Wake on Power	2-32

3

Workstation Operation 3-1

Introduction	3-2
TouchPoint Medical AccessPoint Workstation Base	3-2
Power Supply	3-2
LED Lights	3-3
Keypad Controller	3-4
Keypad Controller LED Battery Fuel Gauge	3-5
Height Adjustable Column/Work Surface Adjustment	3-8
Raising the Workstation	3-8
Lowering the Workstation	3-8
Lowering the Workstation with Elifter	3-9
Keyboard Tray	3-10
Monitor Mount	3-13
Dual Monitor Mount	3-14
Rear Handle	3-14
Casters	3-15
Power Cord	3-15

4

Maintenance and Storage 4-1

Cleaning and Inspection	4-2
Disposal	4-3
Transport and Storage	4-3
Casters	4-3

TroubleshootingA-1

Overview	A-2
Power Supply and Battery	A-3
Low LED Flashing: Battery Nearing End of Charge	A-3
Power Supply Overheating	A-3

Battery Pack Overheating, Critical	A-4
Power Supply Low Temperature	A-4
No Battery Warning	A-5
Short Circuit or Overload	A-5
Power Supply Overheating, Charger Module	A-6
Low Battery Temperature Warning	A-6
Accessories & Equipment Return	B-1
Accessories for AccessPoint Workstations	B-2
Anton Bauer External Power Replacement Kit	B-3
Equipment Return	B-4
Technical Specifications	C-1
Technical Specifications TouchPoint Medical AccessPoint Workstation	C-2
Warranty Information	D-1
TouchPoint Medical AccessPoint™ Standard Limited Warranty	D-2
Resolution Procedure	D-2
Replacement Parts and RMA Policy	D-2
What is Covered	D-3
Warranty Exclusions—What is Not Covered	D-3
Index	Index-1

Page Intentionally Blank

1 Introduction to TouchPoint Medical AccessPoint™ Workstations

Introduction.....	1-2
AccessPoint Product Configurations.....	1-3
Equipment Classification.....	1-4
Important Product Notices.....	1-4
Important Safety Instructions for Installers.....	1-4
Disposal.....	1-5
Intended Use.....	1-6
Chapter Content.....	1-6
Illustrations.....	1-6
Safety Information.....	1-8
Regulatory Compliance.....	1-8
Important Safety Instructions.....	1-8
Notes.....	1-9
FCC Information.....	1-9
Industry Canada.....	1-10
Safety Labels.....	1-10
Revision History.....	1-11
Reference Documents.....	1-12

Introduction

TouchPoint Medical AccessPoint™ has been designed to provide an unmatched user experience to both caregivers and IT professionals. Using a scalable platform, with an array of new ergonomic features and next-generation power options, the workstation provides comfort and convenience for any worker with unparalleled flexibility for long-term value.

All TouchPoint Medical AccessPoint workstations include these features.

- Expandable multi-layer technology tray allows customers to utilize larger scale 17" laptops and future expansion of PC technology or accessories.
- Monitor mount supports a wide variety of display options, including touch screens, all-in-one computers and monitors up to 20 lbs.
- Power supply provides both fan and fan-less charging options as well as ability to perform battery-only upgrades in the future.
- Keypad controller allows customers to easily power the computer on and off without IT involvement while providing access to battery level and lighting controls.
- Ergonomic keyboard tray provides 10° of positive tilt, 20° of negative tilt, 180° of rotation and 8" of independent height adjustment.
- LED lights illuminate work surface and keyboard to provide ample lighting when working in a patient room during night hours.
- Height adjustment mechanism provides strain-free adjustment for a keyboard height range of 23"- 48".
- Easy roll casters provide maximum maneuverability in tight spaces and over thresholds.
- Integrated footrest allows users to relax in a more ergonomic position throughout the day.

These options are also available on selected AccessPoint Configurations:

- Electronic Lifter
- BatteryPro Software
- Dual Monitors
- Ergonomic Push Handles
- APPOC LV Module
- SecureRx Medication Module

NOTE

See the BatteryPro Software Manual, PN L01-565, for detailed information on the BatteryPro software.

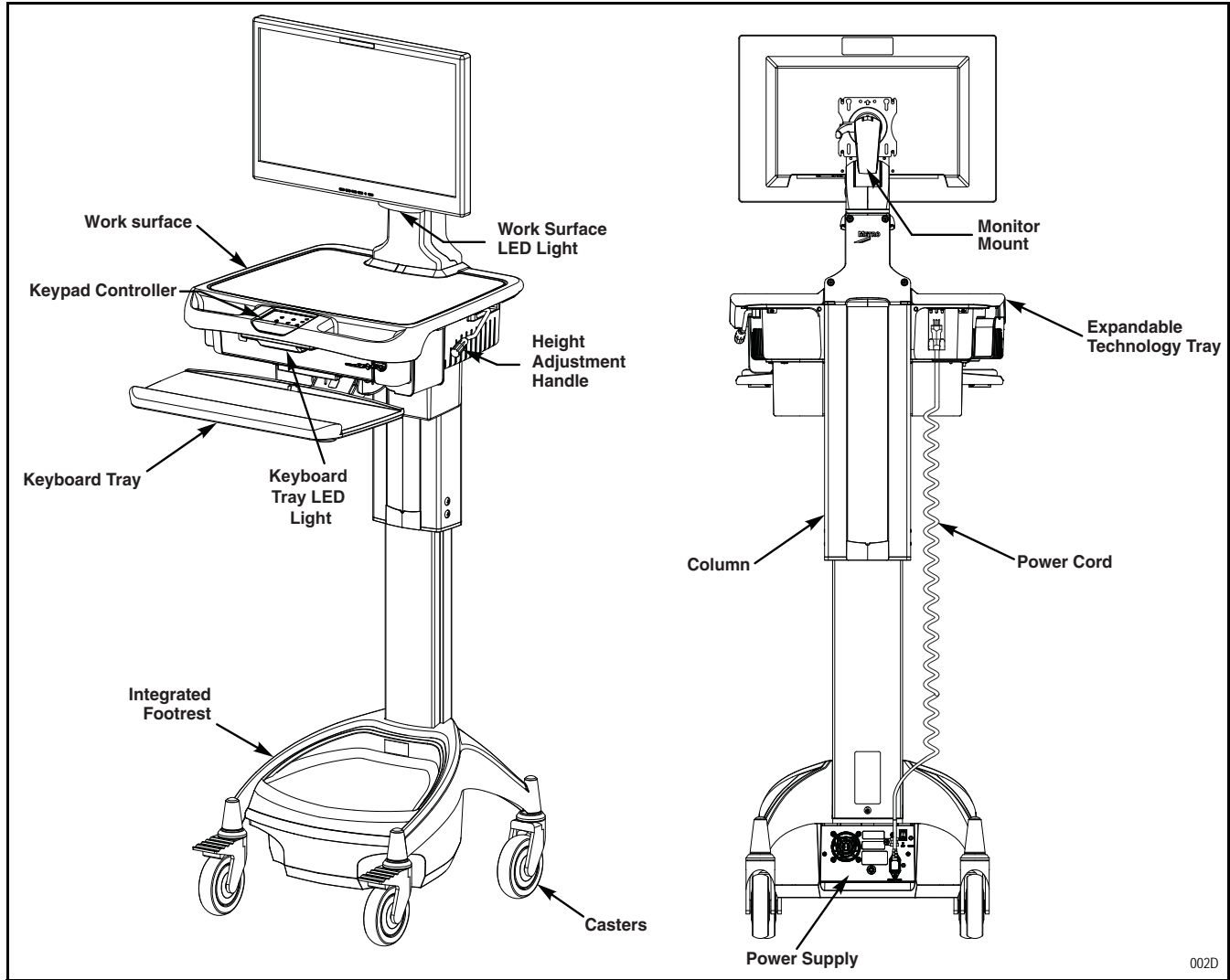

002D

AccessPoint Product Configurations

AccessPoint Model #	AccessPoint Catalogue Product Configuration	Description
APA-100G	Original AccessPoint Core Cart Configuration	AccessPoint, Laptop/SFF Computer Ready, MPS-4010
APA-200G	AccessPoint Lionville Module Configuration	AccessPoint, Laptop/SFF Computer Ready, MPS-4010, LV POC MODULE
APA-200A	AccessPoint Anton Bauer Elora Mobile Power (AC Output) Configuration	AccessPoint, Laptop/SFF Computer Ready, ELORA POWER SUPPLY - AC OUTPUT
APA-300A	AccessPoint Anton Bauer Elora Mobile Power (DC Output) Configuration	AccessPoint, Laptop/SFF Computer Ready, ELORA POWER SUPPLY - DC OUTPUT

Equipment Classification

The TouchPoint Medical AccessPoint Mobile Computing Workstation is Intertek certified with respect to electric shock, fire and mechanical hazards only in accordance with UL 60601-1 and CAN/CSA 22.2 No. 601.1 as Patient Care Medical Equipment suitable for use in patient vicinities.

The Mobile Computing Workstation is Class I Equipment that is also internally powered.

According to the degree of protection against ingress of water, the Mobile Computing Workstation is considered ordinary.

The Mobile Computing Workstation is suitable for continuous operation.

Important Product Notices

The Power Supply used with the AccessPoint Mobile Computing Workstation is provided with a “Hospital Grade” or “Hospital Only” attachment plug for connection to the AC supply circuit.

To ensure equipment grounding reliability, the Power Supply used with the AccessPoint Mobile Computing Workstation should only be connected to AC outlet receptacles, which are marked “Hospital Grade” or “Hospital Only.”

Where the integrity of the external protective earth connector arrangement is in doubt, equipment shall be operated from its internal electrical power source.

Important Safety Instructions for Installers

TouchPoint Medical AccessPoint is available as a fully integrated workstation. When selecting a fully integrated AccessPoint, TouchPoint Medical integrates all computer equipment to comply with rules and regulation of the Intertek certification and delivers a fully functional cart at the customer's site. When a customer does not choose a fully integrated AccessPoint, TouchPoint Medical delivers the core AccessPoint cart and the customer is responsible for integrating their computer equipment.

For safe operation and compliance with the Intertek certification, the installer needs to follow these instructions:



All technology equipment added to the cart must be listed with a Nationally Recognized Test Lab (NRTL) for use in the United States; carry a CE Mark for use in Europe; or carry the appropriate approval marks for the country of intended use.



The maximum continuous output power of a DC system is 150 W and 200 W for a maximum duration of 5 minutes.



The maximum continuous output power of an AC system (use of the AC inverter) is 135 W and 180 W for a maximum duration of 5 minutes.



The base cart is equipped with a Multiple Portable Socket Outlet (MPSO). No additional MPSOs or extension cords shall be used.



The weight of the monitor shall not exceed 20 lbs. In case of dual monitors, the weight of both monitors combined shall not exceed 20 lbs.



The combined weight of the computer equipment (computer, monitor, keyboard, auxiliary equipment, etc.) shall not exceed 35 lbs.



Not following the above instructions and altering of the base cart will void the Intertek certification and is expressly prohibited by TouchPoint Medical.

Disposal

NOTICE

For batteries recycling/disposal in the United States and Canada, contact Call2Recycle.



005D



NOTICE

For other countries, batteries must be recycled/disposed of in compliance with local regulations.

<p>NOTICE</p> <p>Contact Touchpoint Medical Service for product repair or battery replacement. Use of unauthorized service or batteries will void warranty, damage equipment, affect performance.</p> <p>C05-1242</p>	
--	--

007A

Intended Use

The TouchPoint Medical AccessPoint™ Mobile Computing Workstation was designed to be safely used within general patient areas for the purpose of clinical data entry and retrieval. The AccessPoint workstation complies with UL 60601-1 electromagnetic leakage and safety requirements if operated according to the guidelines covered in this manual.

Chapter Content

This manual is organized into the following chapters:

1 Introduction – Provides instructions to access the system and safety information.

2 Getting Started – Provides instructions to unpack and setup your workstation. Includes instructions on setting up Wake on LAN/Wake on Power.

3 Workstation Operation Overview – Describes general workstation operation, options.

4 Maintenance and Storage – Describes operation maintenance and storage information.

Appendix A Troubleshooting – Provides basic troubleshooting information.

Appendix B Accessories & Equipment Return – Includes the user-orderable accessories parts list and equipment return address.

Appendix C Technical Specifications – Includes the AccessPoint workstation technical specifications.

Appendix D Warranty Information – Provides TouchPoint Medical Warranty information.

Illustrations

All illustrations in this manual are provided as examples only. Screens shown in this manual do not necessarily reflect or emulate your exact patient data or the precise appearance of your screen.

In this manual, all names appearing in examples and illustrations are fictitious. The use of any real person's name is purely coincidental.

Conventions

This manual is written with certain conventions designed to make the information understandable and readable. Please familiarize yourself with the following:

- Items in **Bold** text are buttons or switches on the equipment, keyboard keys, or text to be entered.
- *Italicized* items are buttons, labels, options or other fields within the software application.
- References to **Enter** require pressing the **Enter** or **Return** key on the keyboard. Do not type the word enter.
- A keystroke combination is displayed as two key names with a plus sign between them. It requires holding down one key while pressing another key on the keyboard. For example, Press **Ctrl + Enter** means hold the **Ctrl** key while pressing the **Enter** key.
- References to the space bar appear as <**Space**>. The brackets remind you to press the space bar. Do not type the word space.
- References to *click* can be also be performed by touching the touchscreen.

Safety Information

Regulatory Compliance

This system was tested and complies with UL 60601-1, CAN/CSA C22.2 No.601.1 and IEC/EN 60601-1-1 medical safety standards.







The product is certified by Intertek with respect to electrical shock, fire and mechanical hazards only in accordance with UL 60601-1, CAN/CSA C22.2 No.601.1 and IEC/EN 60601-1-1 as Patient Care Medical Equipment suitable for use in patient vicinity.

Attention: Consult accompanying documents.

Important Safety Instructions

This section contains important safety and operating instructions for AccessPoint workstation. Please read all instructions on the workstation before putting into service.

- DANGER**  AccessPoint workstation and the power supply are not for use in hazardous (classified) locations. Do not use nor recharge the power supply battery in oxygen enriched areas; areas where flammable anesthetics are used or stored; or any other hazardous, classified location.
- CAUTION**  User maintenance consists solely of cleaning and minor external adjustments. For safety purposes, all servicing must be performed by qualified service personnel only. For all service items, contact TouchPoint Medical Customer Service.
- CAUTION**  Do not operate the AccessPoint workstation if it has received a severe impact or has been otherwise physically damaged. Have a qualified service person inspect both the AccessPoint workstation in conjunction with its power supply for any performance or safety hazard prior to putting back into service.
- CAUTION**  To prevent damage to any cords or connectors when disconnecting, always grasp and pull by the connector and not the cord. Do not operate the AccessPoint workstation with damaged cords or connectors. Replace the damaged component immediately. Contact TouchPoint Medical Customer Service for replacement parts and service.
- CAUTION**  Risk of Electric Shock - The AC power cord is the only means to disconnect the power supply and AccessPoint workstation from the AC power grid (mains). The ON switch on the power supply does not disconnect from main power.

On the DC power side, the power supply employs either a Li-Nano, SLA, or LiFe batteries to provide mobile DC output power. Low voltage (10-16 VDC) DC power is available from the power supply even when the AC cord is disconnected from an AC outlet. To remove DC power, put the ON switch in the (OFF) position.

CAUTION



The maximum design load (safe working load limit) for the AccessPoint workstation is 5 lbs.(2.2 kg.).

NOTICE

The receiver of this product is responsible for freight damage claims.

- ◆ This equipment must be opened immediately for inspection.
- ◆ All visible damages must be reported to freight co. within 48 hours, and must be noted on freight bill at time of delivery.
- ◆ Concealed damage is your responsibility - you must advise carrier of any loss or damage within 15 days after receipt of material.
- ◆ If there is damage, retain original packaging for inspectors.

Notes

NOTE

Regularly inspect this product. Tighten loose fasteners and replace worn or damaged parts with new TouchPoint Medical approved parts. For mobile units, regularly inspect casters and replace worn or damaged casters immediately.

FCC Information

WARNING



Changes or modifications to this device not expressly approved by TouchPoint Medical could void the user's authority to operate this equipment. Shielded cables must be used with this unit to ensure compliance with the FCC Class A limits.

This device complies with FCC Rules, part 15. Operation is subject to the following conditions:

1. This device may not cause harmful interference, and
2. This device must accept any interference that may be received, including interference that may cause undesired operation.

NOTICE

This equipment has been tested and found to comply with the limits for a Class A digital device, pursuant to part 15 of the FCC rules. These limits are designed to provide reasonable protection against harmful interference when the equipment is operated in a commercial environment. This equipment generates, uses, and can radiate radio frequency energy and, if not installed and used in accordance with the instruction manual, may cause harmful

interference to radio communications. Operation of this equipment in a residential area is likely to cause harmful interference in which case the user will be required to correct the interference at the user's expense.

Industry Canada

This class A digital apparatus meets all requirements of the Canadian Interface Causing Equipment Regulations. Operation is subject to the following two conditions:

1. This device may not cause harmful interference, and
2. This device must accept any interference received, including interference that may cause undesired operation.

Safety Labels

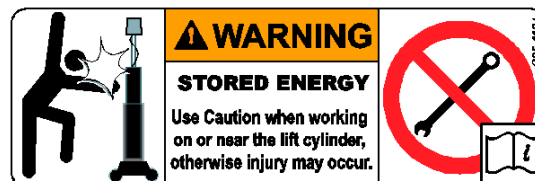
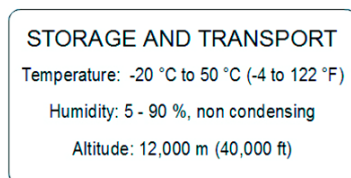
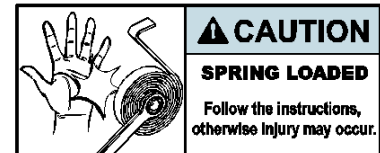

013A

Revision History

Each page of the original operator manual shipped with your system has a revision letter on it. As the document is updated, the revision letter is changed.

Revision	Date	Comments
1.0	08/30/2013	Initial release of AccessPoint Mobile Computing System Workstations.
B	11/17/2014	Includes height adjustment handle and new terminal block location. Dual monitors operation and e-lifter disassembly/assembly procedures are added. Added Laptop cart to this manual
C	05/20/2015	Updated tension spring adjustment procedure.
D	03/01/2016	1) Added references of APPOC LV module and accessories, Anton Bauer RP kit list and non-application of Anton Bauer with dual monitors and APPOC LV modules. 2) Updated manual with single 5" caster photographs and graphics 3) CRN 15-270, 15-319, 15-326 action items are updated.
E	11/11/2016	Updated company branding.

Reference Documents

Literature No	Title	Revision
L01-601	AccessPoint LV Medication Module, Instruction Manual	A
L01-604	AccessPoint LV Medication Module, Illustrated Parts Catalog	A
L01-598	AccessPoint LV Medication Module, Installation Instructions	A
L01-575	Anton Bauer Elora Swappable AC Power Supply Kit, Installation Instructions	A
7595-0447	Anton Bauer Elora Battery Interface, Owner's Manual	B
246-11	Anton Bauer Elora 240 Battery, Owner's Manual	A
L01-565	BatteryPro Software Manual	A

2 Getting Started

Getting Started with the Workstation	2-2
Unpacking	2-2
Inspection.....	2-2
Shipment of Power Supply	2-2
Connect the Power Supply Batteries.....	2-3
Charge Power Supply Battery	2-6
Integration.....	2-8
Computer Power Tips and Cable Connections	2-8
Configure Selectable Voltages	2-10
Remove Work Surface	2-12
Technology Tray	2-13
Route Monitor Cables.....	2-20
Setup Keyboard and Mouse	2-22
Install Work Surface	2-24
Wake on LAN / Wake on Power	2-25
Wake on LAN	2-25
Wake on Power	2-32

Getting Started with the Workstation

Unpacking

After cutting the strapping bands, lift the top of the box over the workstation. In order to avoid any injury, two (2) people should lift the workstation from the padding blocks.

Inspection

After the AccessPoint workstation has been unpacked, inspect the unit for any shipping damage. If there is any damage, contact TouchPoint Medical Customer Service immediately.

Shipment of Power Supply

CAUTION

Before placing the Power Supply (Li-Nano, SLA, LiFe) into service on a AccessPoint workstation, the power supply batteries may need to be connected. Depending on the shipment, they may or may not be connected due to USDOT and IATA regulations.

The Power Supply is available in 3 battery chemistry options. Depending on the battery chemistry, the preparation of the shipment is different.

Lithium Iron Phosphate (LiFe) Battery

The LiFe Mid-grade Battery can be connected or disconnected and requires a fully regulated Class 9 shipment in any shipping mode. The shipper must be certified for Li-Ion Class 9 shipments. The power supply must be shipped per “UN3481, Lithium ion batteries contained in equipment” on cargo aircraft only.

The power supply contains one battery pack. Ratings below given per battery pack:

- ◆ Battery weight: 7.33 kg
- ◆ Wh rating: 512 Wh
- ◆ Equivalent Li Content (ELC): 48 g

Sealed Lead Acid (SLA) Battery

The SLA battery is not considered a Hazardous Material (Dangerous Goods) and there is no restriction on shipping the SLA batteries.

Lithium Iron Nanophosphate (Li-Nano) Battery

Non Class 9 Shipment

In the USA, Li-Nano batteries can be disconnected from the power supply for a regular Ground shipment. The shipping container must have the following marking:

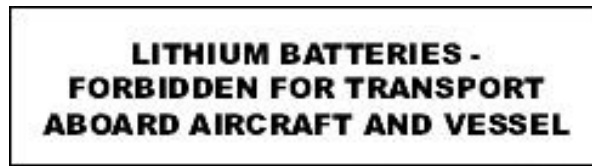

Class 9 Shipment

Outside the USA in any shipping mode and air or sea transport inside the US, the power supply must be shipped as fully regulated Class 9 (Hazardous Material / Dangerous Goods). In this shipping mode the batteries can be connected or disconnected. The shipper must be certified for Li-Ion Class 9 shipments. The power supply must be shipped per “UN3481 Lithium ion batteries contained in equipment” on cargo aircraft only.

Typically, a power supply contains two battery packs. Ratings below given per battery pack:

- ◆ Battery weight: 2.75 kg
- ◆ Wh rating: 264 Wh
- ◆ Equivalent Li Content (ELC): 24 g

Connect the Power Supply Batteries

First plug in power supply and check the status of battery on fuel gauge LED. If the LED flashes as shown in figure below, then connect the batteries

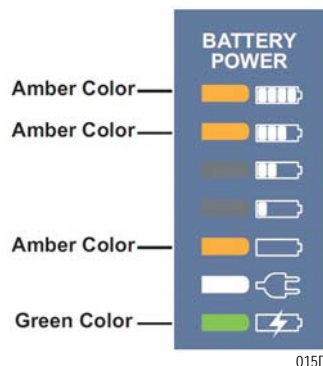

CAUTION

Only qualified service personnel should perform the following procedure for connecting the power supply batteries.

CAUTION

To prevent damage to any cords or connectors when disconnecting, always grasp and pull by the connector and not the cord.

NOTICE

The battery cells may or may not be connected during shipment due to USDOT and IATA regulations. The procedure is required immediately after unpacking before powering up and using the workstation for the first time.

1. Ensure the AC cable is disconnected from the wall outlet and power supply is in OFF (down) position.

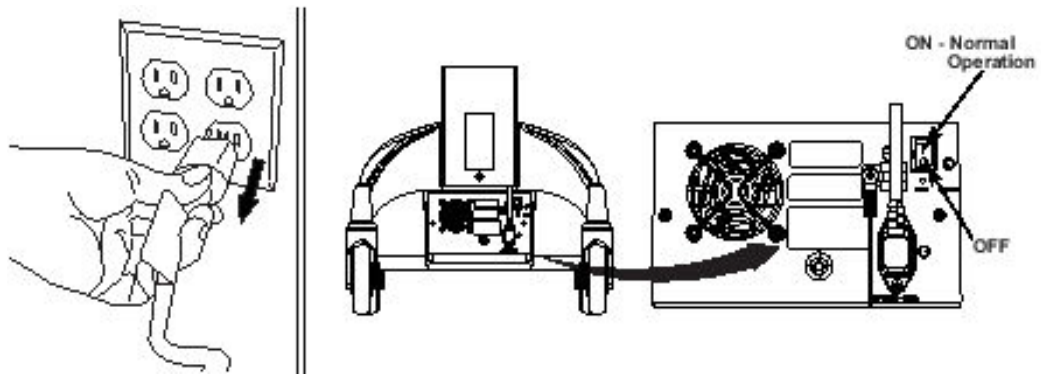

016D

2. Loosen and remove mounting screws (2x) from bottom of base cover as shown below.



017D

- a. Li-Nano Power Supply Batteries: Plug both connectors to the Li-Nano batteries and check for accuracy.

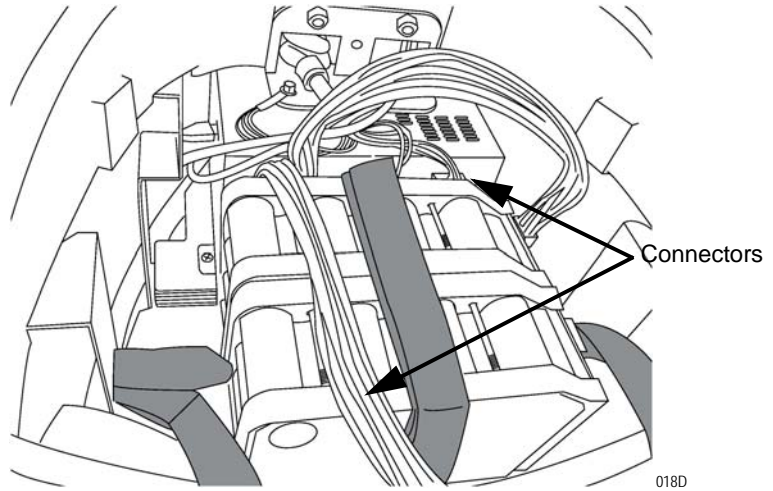

- b. SLA Power Supply Batteries: SLA batteries are always shipped connected as shown below.

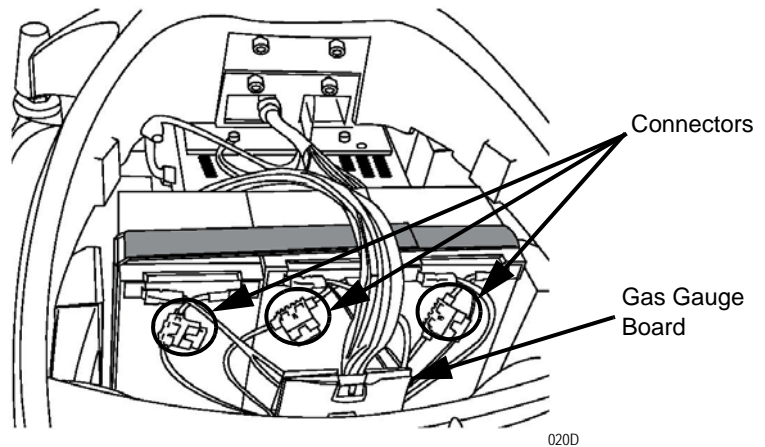

- c. LiFe Power Supply Batteries: Plug the connectors to the LiFe batteries and check for accuracy. Battery connections shown below are from side view for better visibility.

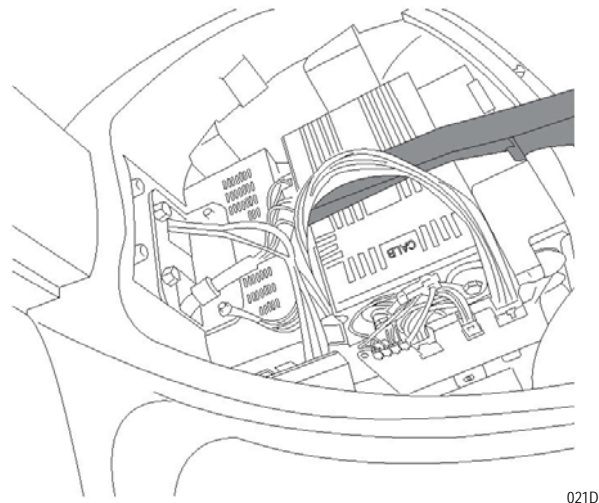

3. Install base cover and tighten the screws (2x) as shown below.

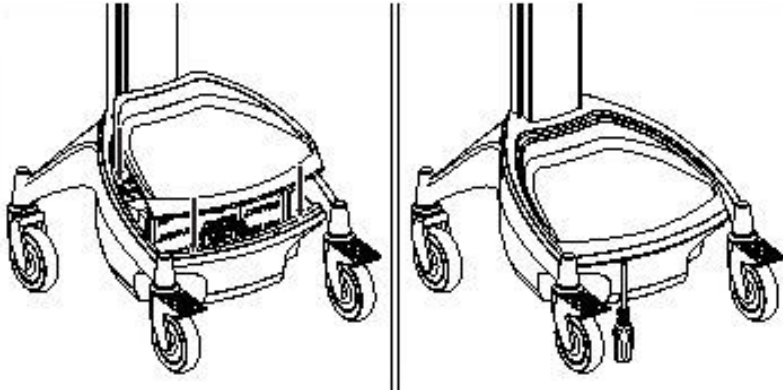

022D

Charge Power Supply Battery

NOTE

The workstation's electrical connections to the monitor, keyboard and technology tray must be made per the AccessPoint Workstation Wiring Diagram. Contact TouchPoint Medical Service for the most current wiring diagram.

Before placing an AccessPoint workstation into service for the first time with the Li-Nano, SLA, LiFe power supply, the power supply battery should be initially charged at least 8 hours. To charge the battery, plug the coiled AC power cord into an AC outlet and put the ON/OFF switch into the "ON" position which is located on the back of power supply as shown below.

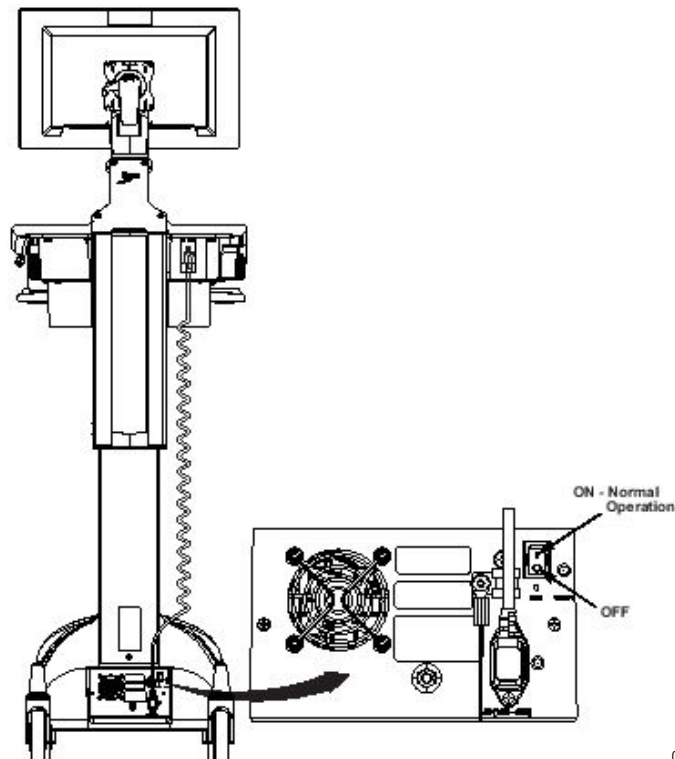

023D

In the “ON” position, the power supply provides power to the AccessPoint workstation. If the workstation is not being used for an extended period of time, the ON/OFF switch should be put in the OFF position. The switch position disconnects the battery from any internal or external equipment and avoids deep discharges of the battery, which can cause damage to the battery.

WARNING

Risk of Electric Shock - The power supply employs a Lithium Ion Nano-Phosphate (Li-Nano) battery to provide mobile DC output power. Low voltage (11-15V) DC power is available from the power supply even when the AC cord is disconnected from an AC outlet. To remove DC power, put the ON/OFF Switch in the “OFF” position.

NOTE

After the initial charge, the charge time from a completely discharged battery is typically **2 hours** in fan mode and **3 hours** in fan less mode with LiFe and Li-Nano and **4 hours** for SLA regardless of fan mode.

NOTE

If the Power Supply has been switched to “OFF” for more than **1 week**, connect the workstation to AC to wake up the power supply before.

Integration

If the facility chooses BlueCHIP Integration, the AccessPoint workstation will arrive fully assembled and fully functional at the customer's site (most accessories do not ship assembled to the workstation).

However, if the facility has not selected BlueCHIP Integration, follow the instructions in this section to integrate your workstation.

Computer Power Tips and Cable Connections

Computer Power Tips							
Tip No.	Voltage	Computers	Tip No.	Voltage	Computers		
MT2	12V	Praim XP9400-A, Thin Client	MT41	19V	Acer Veriton Z2610, All in One		
		Praim I10, Thin Client			AOPEN DE5100, Mini PC		
		IGEL UD3, Thin Client			Lenovo M72 Tiny, Mini-PC		
		IGEL UD5, Thin Client			Lenovo M92 Tiny, Mini-PC		
		IGEL H700C, Thin Client			Nexlink Mini X11, Mini-PC		
		Motion Computing C5, Tablet			Tangent Rugged Mini VI (Bar 106), Mini-PC		
		Wyse C90LE, C90LEW, C90LEW7, Thin Client			Tangent Rugged Mini UT, Mini-PC		
MT2	16V	Panasonic H2, Tablet					Tangent Rugged Mini N, Mini-PC
MT5	19V	HP t510, Thin Client					Tangent Vita LT, All in One
		HP t5565, Thin Client					Tangent Vita 2000SA, All in One
		HP t5740, Thin Client					Wyse D90D7, Thin Client
		Seneca MP-57, Mini-PC					Wyse R90L, R90LW, Thin Client
		Tangent Medix T19B, All in One					Wyse V90LE, V90LEW, Thin Client
		Tangent Medix T19i, All in One					Wyse Z90LE, Z90LEW, Z90D7, Z90DW, Z90SW, Thin Client
		Tangent Medix T22a, All in One			Zotac ZBOX HD-ID40, Mini-PC		
		Tangent Medix T22i, All in One		MT44	19V	All Lenovo Laptop computers	
		Tangent Rugged Mini 965, Mini-PC		MT55	19V	All HP Laptop computers	

Computer Power Tips					
Tip No.	Voltage	Computers	Tip No.	Voltage	Computers
MT23	19 V	All Dell E Series laptop computers	MT41	16V	Panasonic H1, Tablet
MT41	12V	Tangent Rugged Mini I, Mini-PC			Panasonic CF-51, Laptop
		Tangent Rugged Mini VA, Mini-PC			Panasonic T7, Laptop
		VXL Itona F24, Thin Client			Panasonic CF-18, Laptop
					Panasonic CF-19, Laptop

Tip Dimensions	
Tip #	Tip Size
MT #2	ID 2.10 mm, OD 5.50 mm & 11.00 mm long
MT #5	ID 1.60 mm, OD 4.80 mm & 11.00 mm long
MT #23	ID 5.00 mm, OD 7.40 mm & 12.50 mm long
MT #41	ID 2.50 mm, OD 5.50 mm & 12.50 mm long
MT #44	ID 5.45 mm, OD 7.90 mm & 11.50 mm long
MT #55	ID 5.00 mm, OD 7.40 mm & 12.50 mm long
Computer Power Cables	
Voltages	Computer
19V	HP 7800, 7900, 8000, 8200, 8300 USDT Computer
	HP t610, Thin Client
	HP 6000, 6300, 8200, 8300 ELITE, All in One
12V	Tangent Medix 1500, 1700SF, 1900SF, All in One
19V	Tangent Rugged Mini GM, Mini-PC
19V	Tangent Rugged Mini VI (Bar 105), Mini-PC
	Tangent Vita 2150, All in One
AC	Dell Optiplex 780/790/7010/9010, USFF
	Dell FX-160, Thin Client
	HP 6300/8300 Elite, All in One
	Lenovo A70Z, M71Z, M72Z, All in One

Configure Selectable Voltages

1. Request a link from TouchPoint Medical Customer Service to download BatteryPro400.
2. Install BatteryPro400 on a laptop computer to change the voltage(s).
3. Connect the computer to via USB to the power supply.
4. Start BatteryPro400 and right click on the BatteryPro400 icon (grey battery icon).



5. Select *Open Power Properties*.
6. Hold down the CTRL key and click on the *TouchPoint Medical* label. The Diagnosis tab opens.



7. In order to change the selectable voltage on Diagnosis tab:
 - a. Click on *DC1 Setting* for 12-24 V (DC1) or

- b. Click on *DC3 Setting* for 5-10 V (DC3).

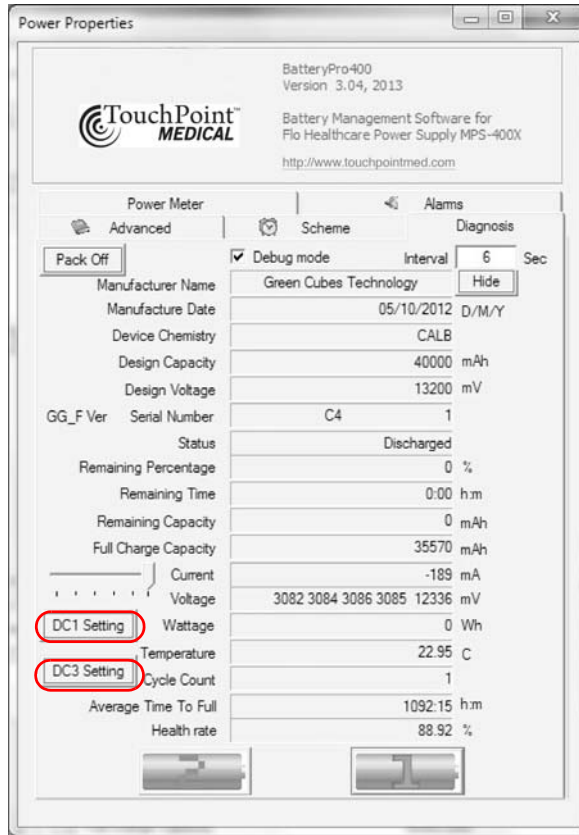

026A

8. With the slider select the desired voltage. After selecting the voltage click *Confirm*.
9. To confirm the voltage change, click *YES*.

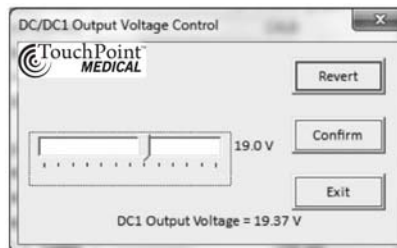

DC 1 Setting

027A

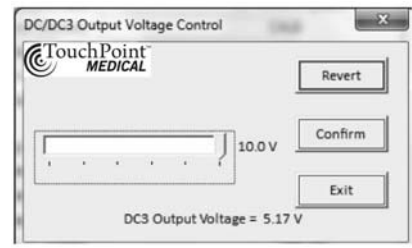

DC 3 Setting

028A

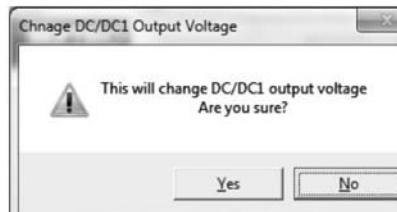

Remove Work Surface

1. To open the work surface, rotate the key in clockwise direction 90° as shown below.

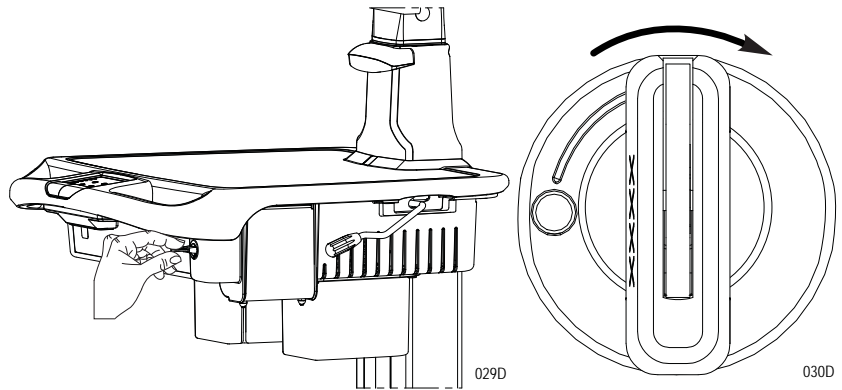

2. Slightly lift up the front of the work surface as shown below.

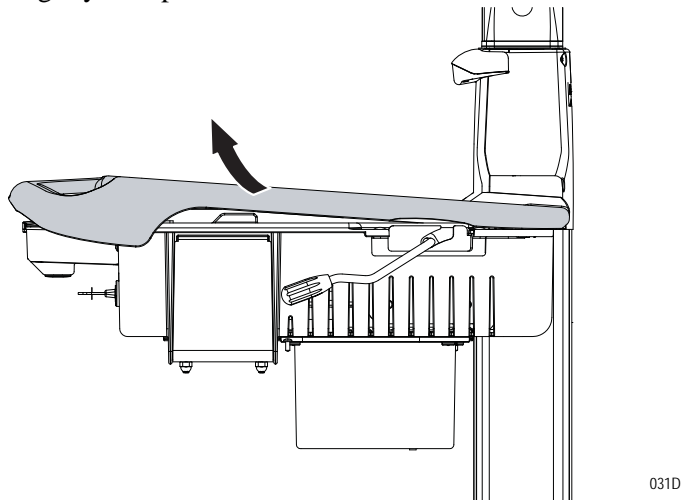

3. Slide the work surface towards the front of the workstation and then remove the work surface from the technology tray.

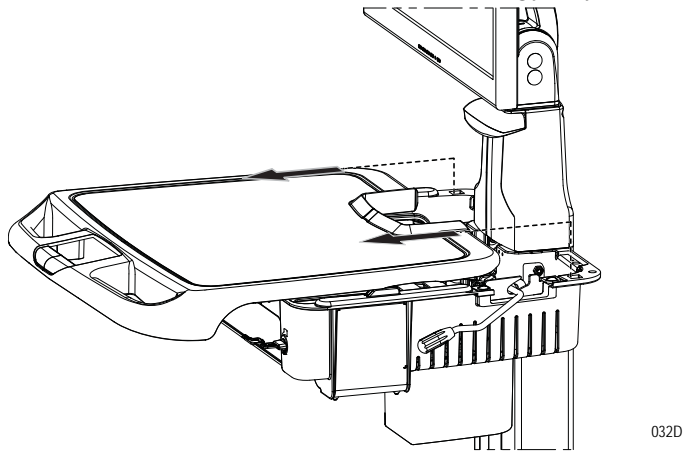

Technology Tray

The expandable tech tray cover is integrated with tech tray to allow easy expansion of a 17" laptop or accessories. The cover can be accessed from the left side of the workstation to integrate future upgrades.

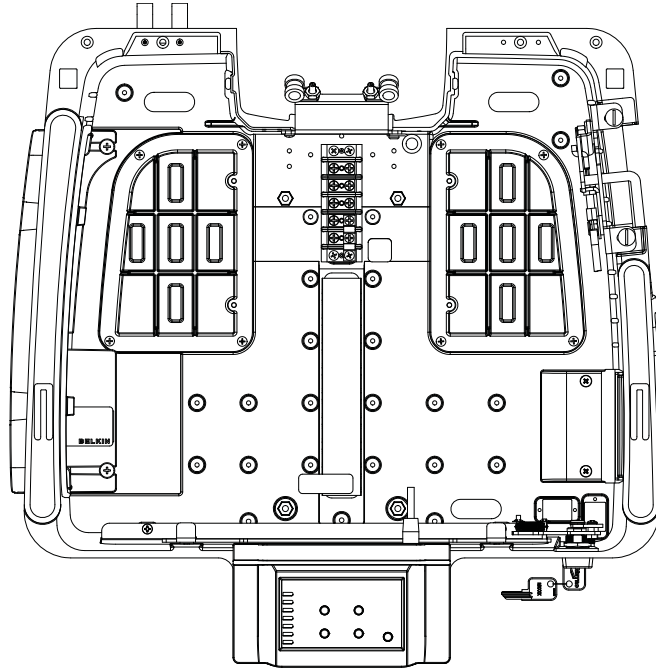

033D

Below are the keypad connections in the technology tray.

Keypad Connection	Description
Wake on LAN (RJ45)	Ethernet CAT5 cable to computer for Wake on LAN operation
Fuel Gauge	Ethernet cable from the power supply to display charge level of battery
Power Lifter	Connection to power lifter (if equipped)
Work surface light	LED light for work surface
Keyboard light	LED light for Keyboard
Wake on LAN Power	Plug for Computer power cable, when using Wake on LAN to turn on computer
Wake on Power	Plug for Computer power cable, when using Wake on Power to turn on computer

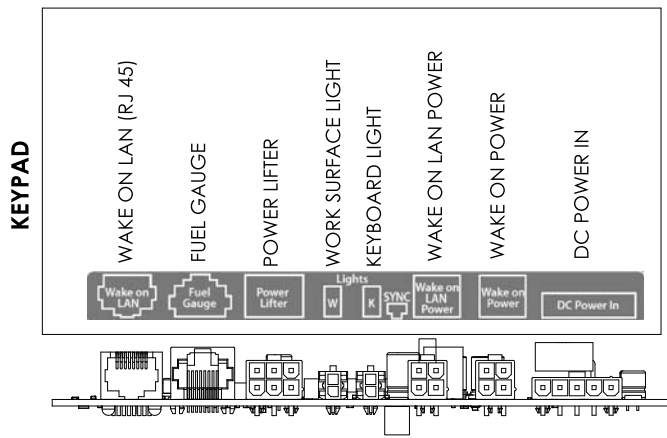

034D

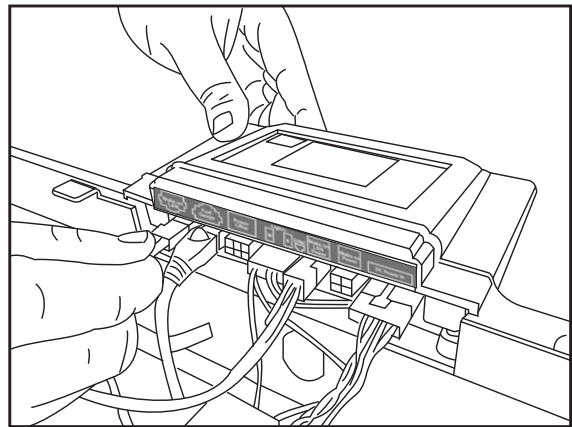

035D

Following table gives respective wire connections in technology tray terminal block and identifying connections.

Position	Designation	Color	Description
Mounting Screw (MS)	Chassis Ground	Green	Chassis ground connection to connect the top and bottom metal structure of the workstation
1 and 2	Return (-)	Black	Workstation power return wire.
3	Unregulated	Yellow	Unregulated output voltage of the power supply. 10.5 - 15 V, 150 W continuous, 200 W peak power
4	Selectable 12-24 V	White	Voltage is selectable via BatteryPro between 12 and 24 V. 150 W continuous and 200 W peak power, Default voltage is 19 V
5	Selectable 5-10 V	Red	Voltage is selectable via BatteryPro between 5 and 10 V. 2 A maximum current. Default voltage is 5 V.

The total power of the power supply is 150 W continuous and 200 W peak.

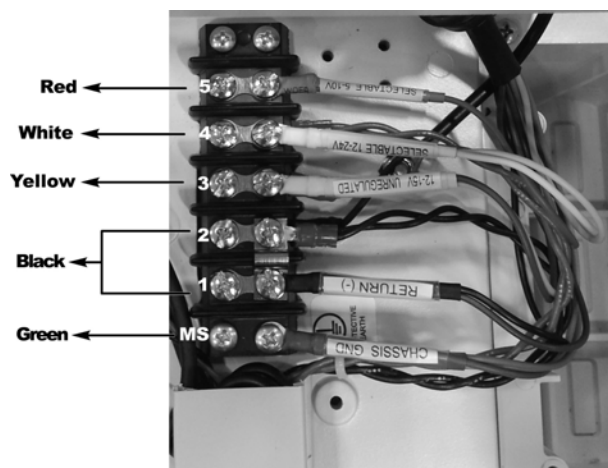

036D

The following table gives wire connections between Terminal Block and AC Inverter and identifying connections.

Terminal Block	AC Inverter
Position 3, Unregulated Voltage, Yellow	Positive (Red)
Position 1 or 2, Return (-), Black	Negative (Black)

AC Inverter Technical Specifications

- Output voltage: 120 VAC, 60 Hz
- Output power: 150 W
- Modified Sinewave

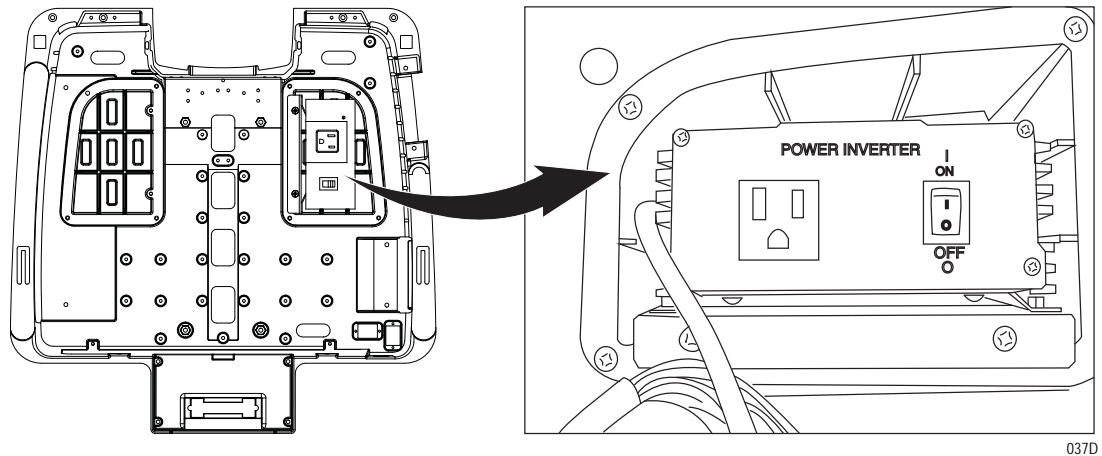

Set up a Computer in the Technology Tray

1. The technology tray offers a computer tray with rubber padding. Seat the computer on the tray and tie it down with the Velcro strap.
2. Computer power with DC.
 - a. Select correct tip for the computer (see [“Computer Power Tips and Cable Connections”](#) on page 2-8).
 - b. Connect computer power cable to the terminal block.
 - ◆ Positive lead to “Selectable output voltage 12-24 V” (Position 4, white)
 - ◆ Negative lead to Return (-) (Position 1 or 2, black)
 - c. Set the power supply to the correct computer voltage (see [“Computer Power Tips and Cable Connections”](#) on page 2-8), if the voltage is different from 19 V using BatteryPro.
 - d. Plug in Computer Power Tip into the Computer Power Cable.
 - e. Plug in computer.

3. Computer power with AC
 - a. Plug in AC adapter in outlet strip
 - b. Stow AC adapter in left pod
 - c. Plug in computer
4. Plug video cable into the computer (Display port, mini display port, HDMI, mini HDMI, VGA). Use adapter cable if necessary.
5. Connect accessories like USB hub, mouse, keyboard, barcode scanner, etc. to the computer.

Set up the Monitor and AIO Computer

1. Attach Monitor or AIO computer to VESA plate (i.e., first attach top 2 screws and hang on VESA bracket).
2. Plug in and ensure adequate range of motion.
3. Remove rear union cover.
4. Remove front plastic plate.
5. Route cables down neck of monitor mount.
6. If AC - plug directly into Inverter or AC power strip.
7. If DC - connect to terminal block.
8. Bundle cables with ties to avoid pinching.
9. Adjust arm for tension.
10. Reattach union cover.

NOTE

To prevent screw from cross threading, back thread screw until you hear a click and then proceed to tighten.

11. Replace front plastic cover.

Inspect Casters

Regularly inspect the casters. Tighten loose fasteners and replace worn or damaged parts with new TouchPoint Medical-approved parts. Replace worn or damaged casters immediately.

Monitor Knuckle Tension Adjustment

Reposition Handle Lever

The handle lever, used to adjust the tilting feature, can be repositioned for optimal comfort.

1. Pull out handle lever in the direction of the straight arrow.
2. Twist handle lever to optimal comfortable position.
3. Release the handle lever.

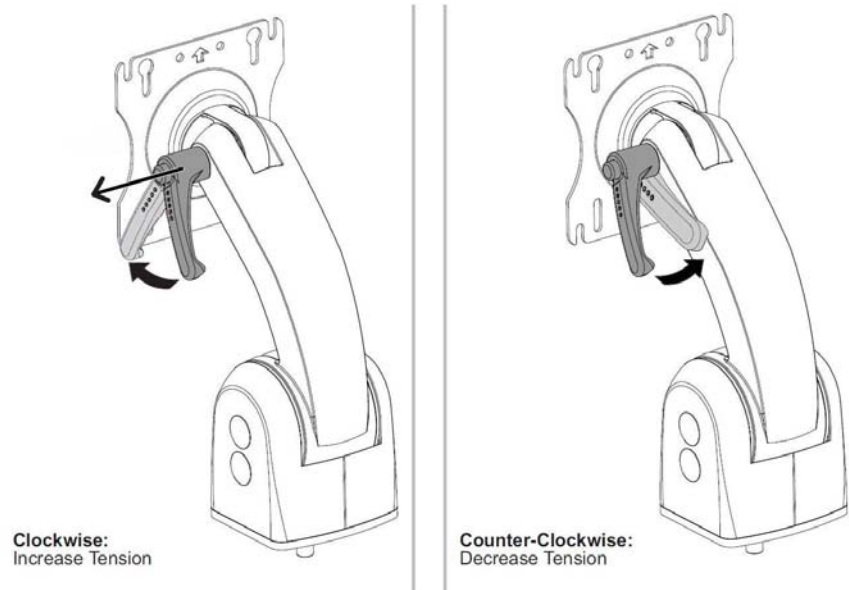

038D

Adjusting the Balance Spring Force

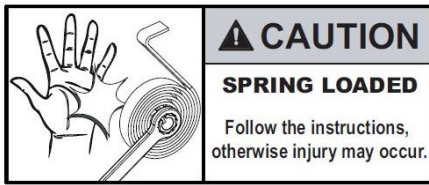

039D

Monitor mount counterbalance force is created by spring tension. If the following procedure is not followed, the spring may cause the wrench to slip without warning and injury may occur.

Increase the counterbalance spring force

1. Remove front cover and move aside monitor input cable and video cable (if present) with screw driver to access gear nut.

CAUTION

Do not release wrench until lever drops into place. Injury may result.

2. With a 9/16" box end wrench, grip the tension gear nut. Rotate tension gear nut clockwise (about 25°) until the lever clicks into the next forward position.

Gently release the tension gear nut as it can rotate counterclockwise (no more than 10°) as it catches and locks into position.

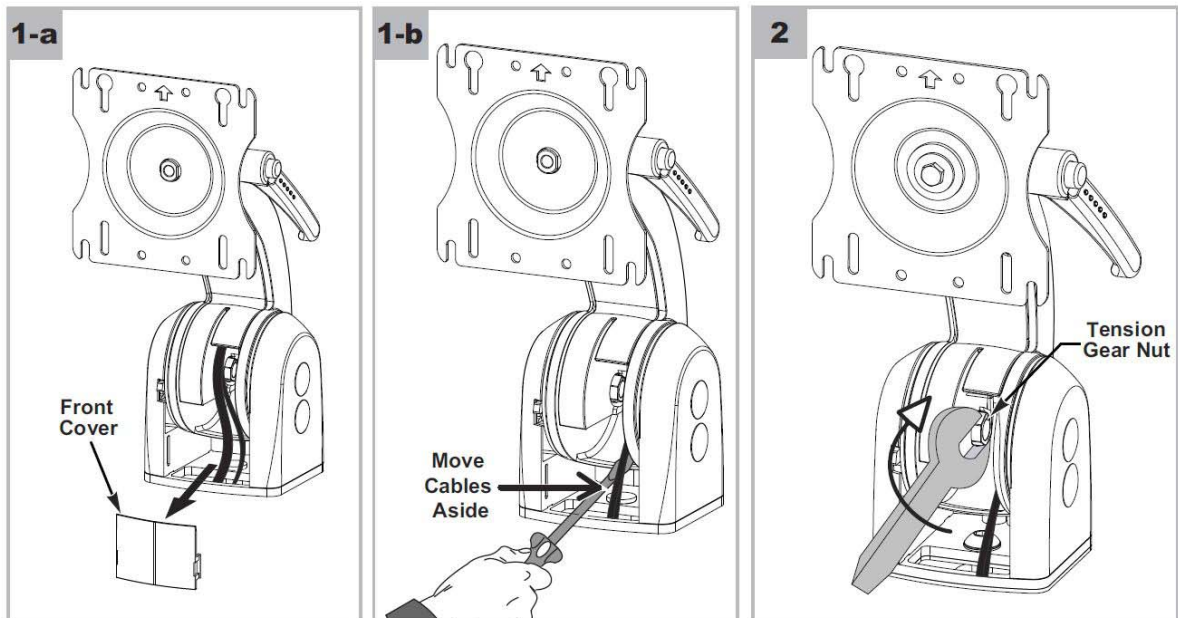

040D

3. There are four functional positions for use with various weight monitors. Position #1 is for mounting lighter-weight monitors and Position#4 is for heavier monitors.

NOTE

Note the orientation of notch to identify position.

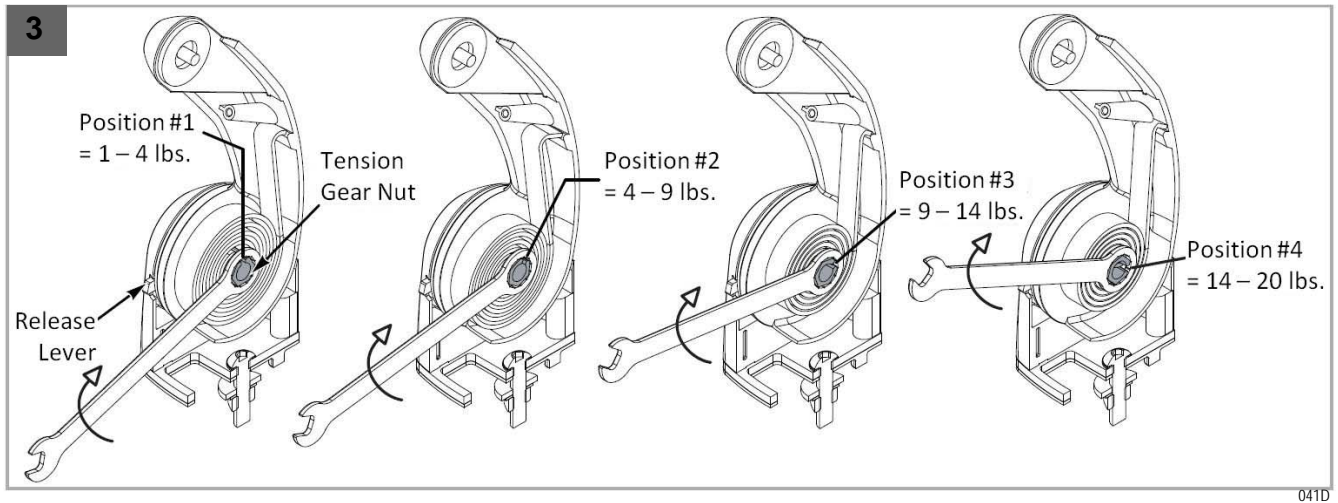

Decrease the counterbalance spring force

1. Remove front cover and move aside monitor and video cables, if present, with screwdriver to access gear nut.
2. With a 9/16" box end wrench, grip the tension gear nut.
3. Slightly turn the tension gear nut clockwise (about 10°).
4. Push/depress the release lever on front arm and allow the tension gear nut to rotate counterclockwise (about 25°) until the tension gear nut is in the previous position.
5. Stop pushing/depressing the release lever. Gently let the tension gear nut rotate counterclockwise (about 10°) and lock into place.
6. Follow 3 for to attain other mounting load limits.

Monitor Counter-Balance Fine Adjustment

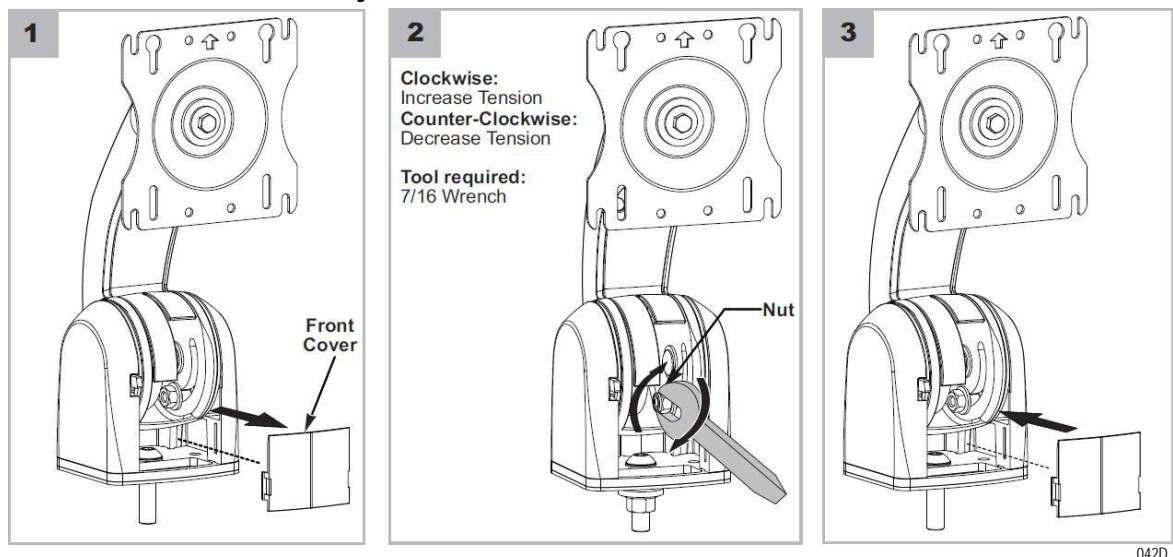

Route Monitor Cables

1. Remove screws (4) and remove rear cover.

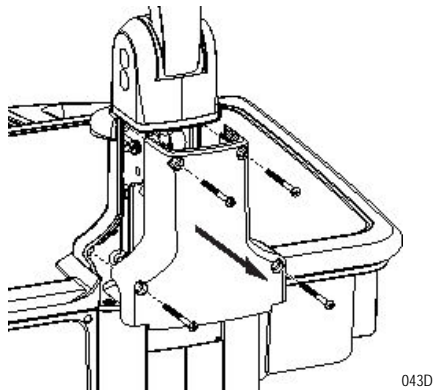

2. Access monitor input cable and video cable from rear enclosure.

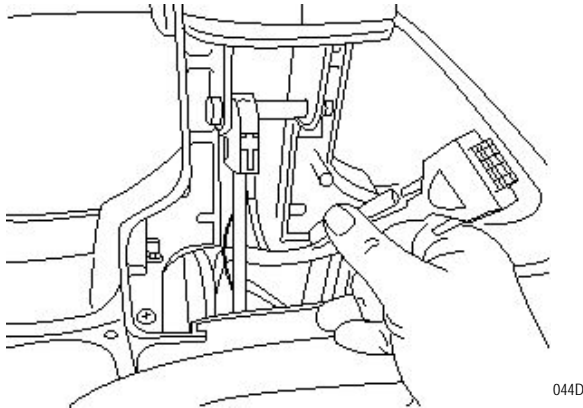

3. Route the monitor input cable and video cable from the monitor arm and connect to the monitor.

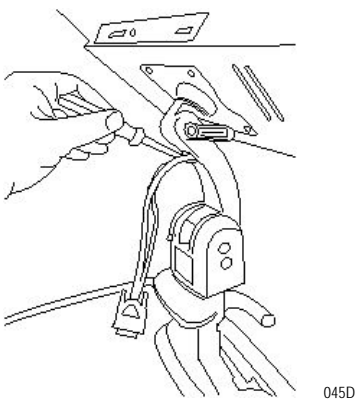

4. Replace the rear cover with screws (4).

NOTE

For information on adjusting the monitor arm, see [“Monitor Knuckle Tension Adjustment”](#) on page 2-17.

Set up Powered USB Hub

1. Set up for DC power.
 - a. Attach ring terminals to the USB hub power cable or use USB power cable (provided by TouchPoint Medical).
 - b. Connect USB power cable to terminal block
 - c. Positive lead to “Selectable output voltage 5-10 V” (Position 5, red)
 - d. Negative lead to Return (-) (Position 1 or 2, black)
 - e. Check that the selectable voltage (red, position 5) is 5 V. If not, change the voltage to 5 V using the BatteryPro software.
 - f. Plug USB power cable into the USB hub.
2. Set up for AC power.
 - a. Plug the USB hub's AC adapter in the AC outlet strip.
 - b. Plug in the AC adapter's DC output into the hub.

Cable Management

1. Lift computer tray (with or without computer tied down) and secure with pin for easy access.
2. For a clean look inside the technology tray, stow excess cabling and AC adapters into the pods.
3. Keep all wiring underneath the computer tray.
4. Hide wiring in the wire conduit running through the center of the technology tray.
5. Attach white anchors as required and tie down loose wires or cables.

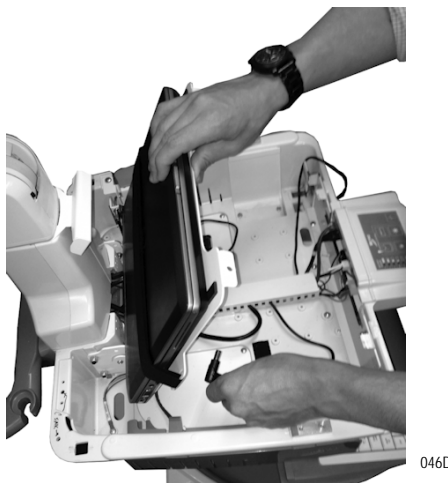

Setup Keyboard and Mouse

1. Place the keyboard on the keyboard tray and attach a cable tie mount to the keyboard tray allowing enough slack for the mouse to reach both left and right mouse pads effectively. Use a small zip tie to secure the cables to the cable tie mount as shown below.

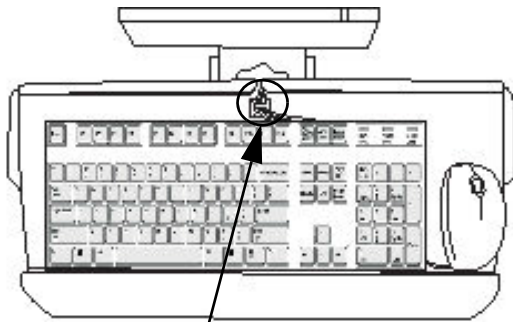

047D

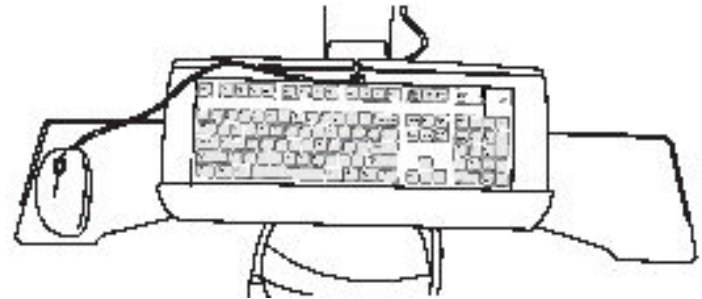

048D

Cable tie mount

2. Attach a second cable tie mount to the back of the keyboard tray as shown below. This prevents the wiring from interfering with the keyboard arm while maneuvering.

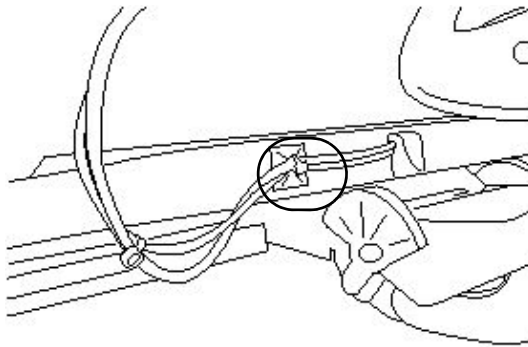

049D

3. Provide enough slack in the wiring for the keyboard arm to pivot 90 degrees from the center home position and attach a cable tie mount on the bottom of the technology tray.

NOTE

Before attaching the cable tie mounts to the technology tray, clean the area where you intend to apply it with an alcohol prep to get a permanent bond with the exterior coating.

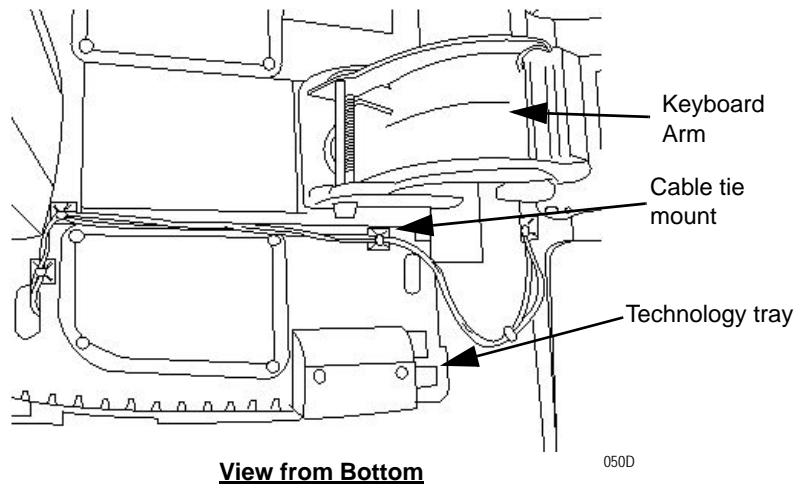

4. Another two sets of cable tie mounts are attached at the back of the technology tray as shown below.
 - ◆ First cable tie mount guides the wire between the keyboard arm track and the storage pod.
 - ◆ Second cable tie mount lines up with the wiring slot to be accessed inside the technology tray and connected to the USB hub.
 - ◆ The wire should be relatively tight to prevent any snags or interference.

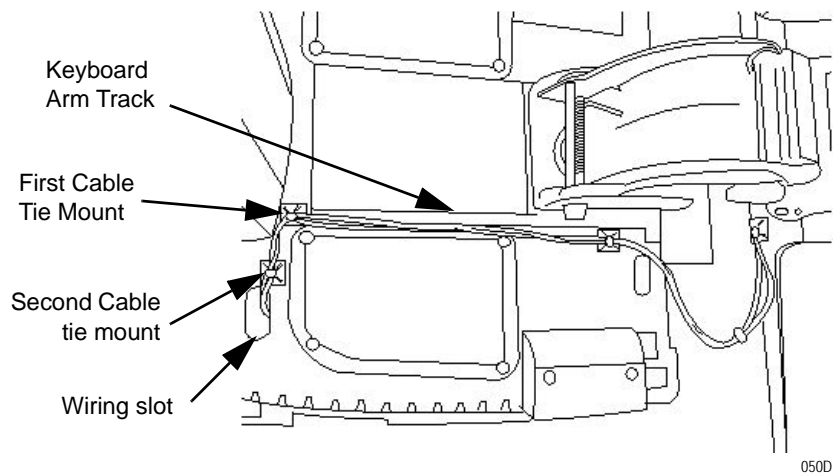

5. Route the wires inside the technology tray and connect the USB keyboard and mouse wires to USB hub. Finally connect USB hub to CPU as shown below.

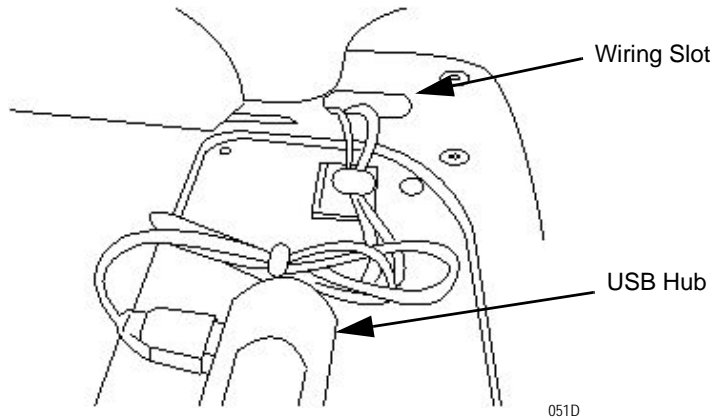

Install Work Surface

1. Slide the work surface towards the workstation technology tray and insert in the square slot as shown below.

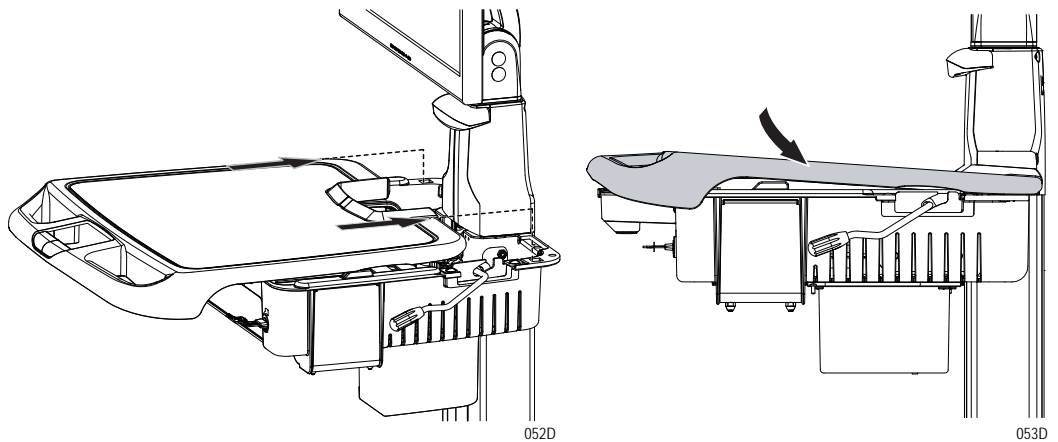

2. To lock the work surface, rotate the key in counter-clockwise direction 90° as shown below.

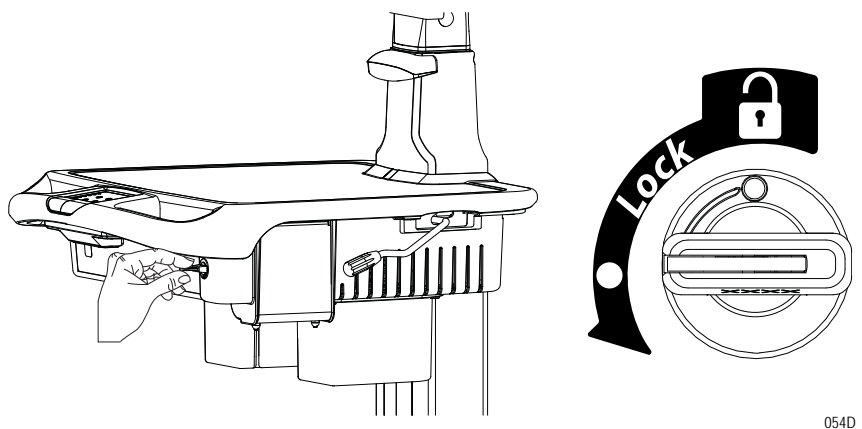

Wake on LAN / Wake on Power

Most computers are equipped with Wake on LAN or Wake on Power (Wake on AC). The AccessPoint workstation takes advantage of these features to turn on the computer from the keypad as shown below, while the computer is locked away inside the technology tray of the workstation.

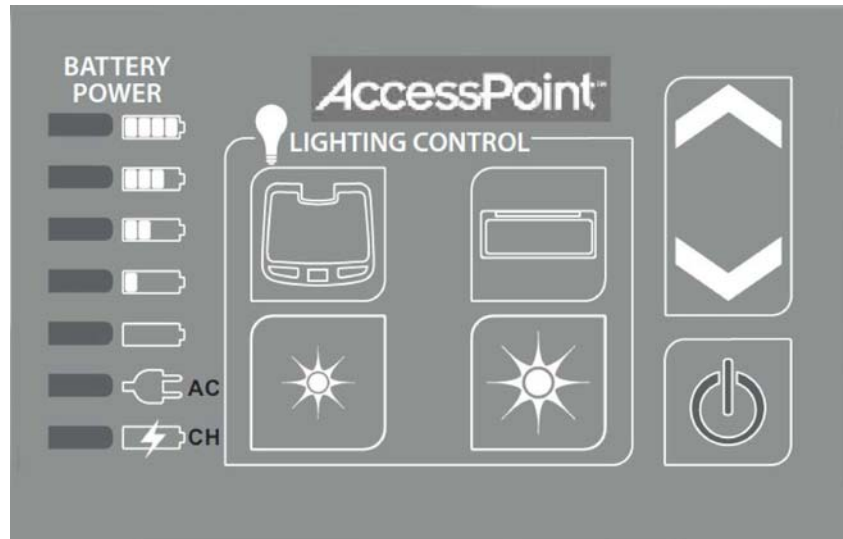

055D

Independently, if the computer is connected with Wake on LAN or Wake on Power, pressing the standby button will turn the computer ON. The standby button illuminates in green as long as the computer is running. Holding the standby button for 5 seconds will shut down the computer if the computer's internal battery is not installed. However, it is strongly recommended to shut down the computer using the Windows START button and selecting *Shut down*.

Wake on LAN

Functioning

If Wake on LAN is selected in the computer's BIOS, the computer's Ethernet port waits to receive the Magic Packet. Once received, it will signal the computer ON.

Before Wake on LAN works with the AccessPoint workstation's controller, the computer and the controller must be synchronized. Once the computer has booted up to Windows, the SYNC button must be pressed. During the SYNC process, the controller obtains the MAC address from the computer.

After pressing on the standby button, the AccessPoint workstation controller sends the computer's MAC address as well as the Magic Packet via the Ethernet cable to the computer to turn the computer ON.

Wake on LAN Setup

Plug the computer power cable into the Wake on LAN Power plug and plug the Ethernet cable in the Wake on LAN Ethernet port. See layout below.

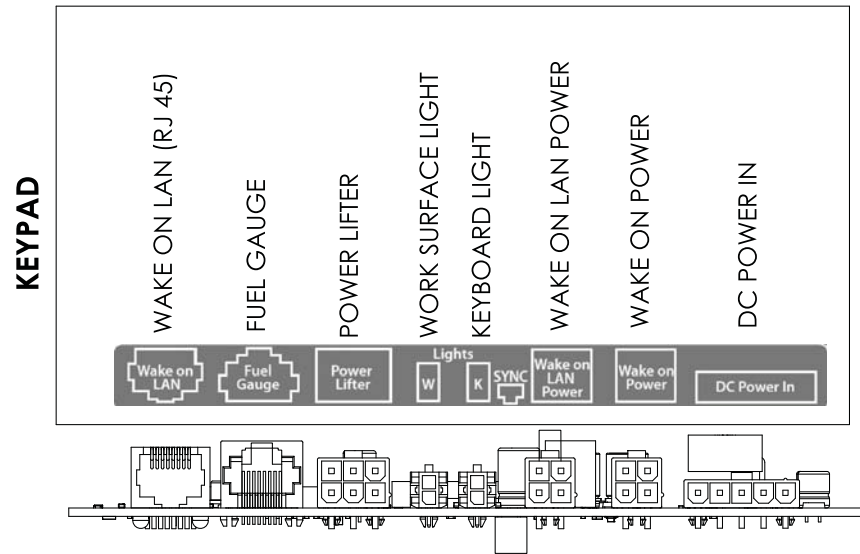

034D

Setup for Dell Laptop Computers

1. Connect power tip MT23 (marked "23") to computer power cable and plug in computer.

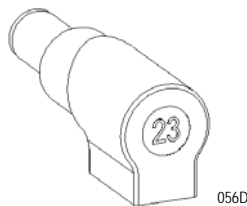

2. Turn on the laptop computer by pressing its standby switch.
3. As soon as the Dell Splash screen appears, press *F2* to access the laptop's BIOS.

4. Select *Power Management* and *Wake on LAN/WLAN*. Enable *Wake on LAN only* as shown below.

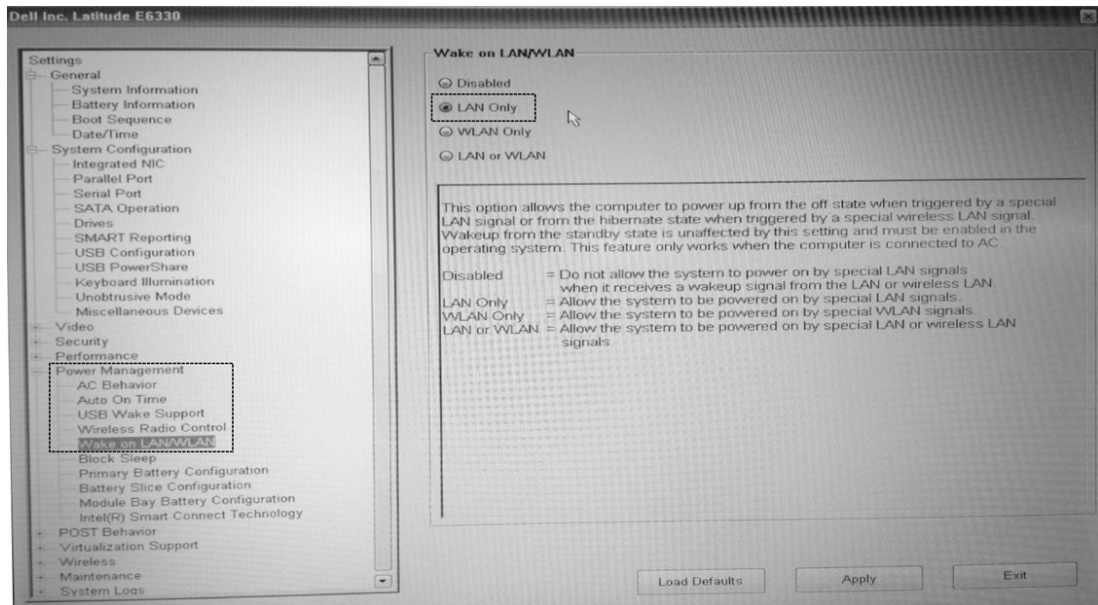

5. Save BIOS changes and boot the computer into Windows.
6. Press the SYNC button to acquire the computer's MAC address.
7. The standby button's light will flash rapidly. Once the MAC address is acquired, the light will be solid for 3 seconds, off for ½ second and then stay on due to the computer's current draw.
8. If the Keypad Controller was not able to acquire the MAC address, the standby button's light will flash rapidly for several seconds and then it will go off or 3 seconds, on for ½ second and then stay on due to the computer's current draw. If the sync fails, most likely the Ethernet cable is not plugged into the computer and/or the Keypad Controller.
9. Open the Windows Device Manager.
 - a. Under Network Adapters, select the Ethernet connection (Typically it is an Intel Gigabyte Network Connection).
 - b. Right click and select *Properties*.
 - c. Click on the *Power Management* tab.

d. Check *Wake on Magic Packet*.

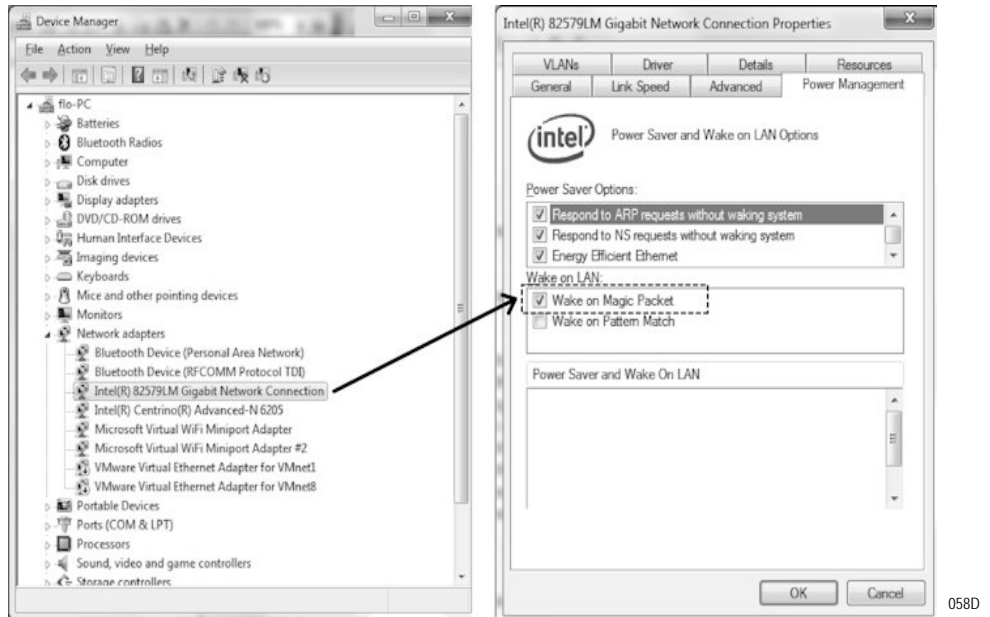

10. Shut down the computer using the Windows shutdown feature.

11. Turn on the computer via the keypad's standby button.

Setup for HP Laptop Computers

1. Connect power tip MT55 (marked "55") to computer power cable and plug in computer.

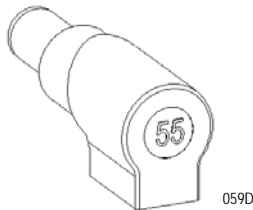

2. Turn on the laptop computer by pressing its own standby switch.
3. As soon as the HP Splash screen appears, press *F10* or *ESC* to access the laptop's BIOS.

4. Select *System Configuration*, *Device Configurations* and *Wake on LAN*. Check *Follow Boot Order* as shown below.

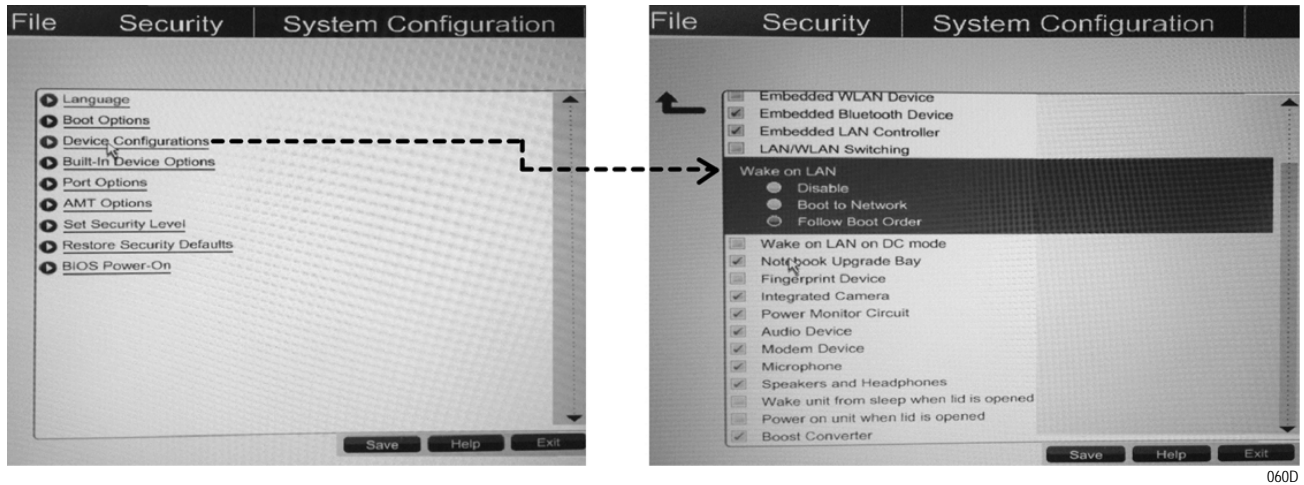

5. Save BIOS changes and boot the computer into Windows.
6. Press the SYNC button to acquire the computer's MAC address.
7. The standby button's light will flash rapidly. Once the MAC address is acquired, the light will go solid for 3 seconds, off for ½ second and then stay on due to the computer's current draw.
8. If the Keypad Controller was not able to acquire the MAC address, the standby button's light will flash rapidly for several seconds and then it will go off or 3 seconds, on for ½ second and then stay on due to the computer's current draw. If the sync fails, most likely the Ethernet cable is not plugged into the computer and/or the Keypad Controller.
9. Open the Windows Device Manager.
 - a. Under Network Adapters, select the Ethernet connection (Typically it is an Intel Gigabyte Network Connection).
 - b. Right click and select *Properties*.
 - c. Click on the *Power Management* tab.

d. Check *Allow this device to wake the computer*

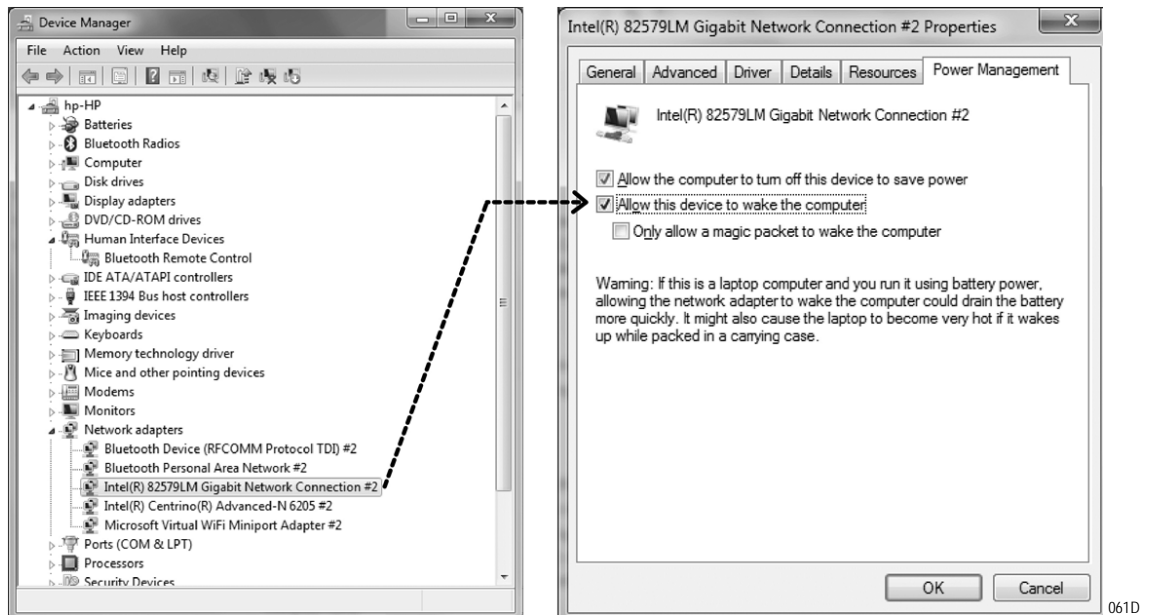

10. Shut down the computer using the Windows shutdown feature.

11. Turn on the computer via the keypad's standby button.

Setup for Lenovo Laptop Computers

1. Connect power tip MT44 (marked "44") to computer power cable and plug in computer.

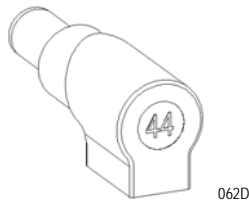

2. Turn on the laptop computer by pressing its own standby switch.
3. As soon as the Lenovo Splash screen appears, press *F1* to access the laptop's BIOS.

4. Select *Config* and *Network*. At *Wake On LAN* select *AC Only* as shown below.

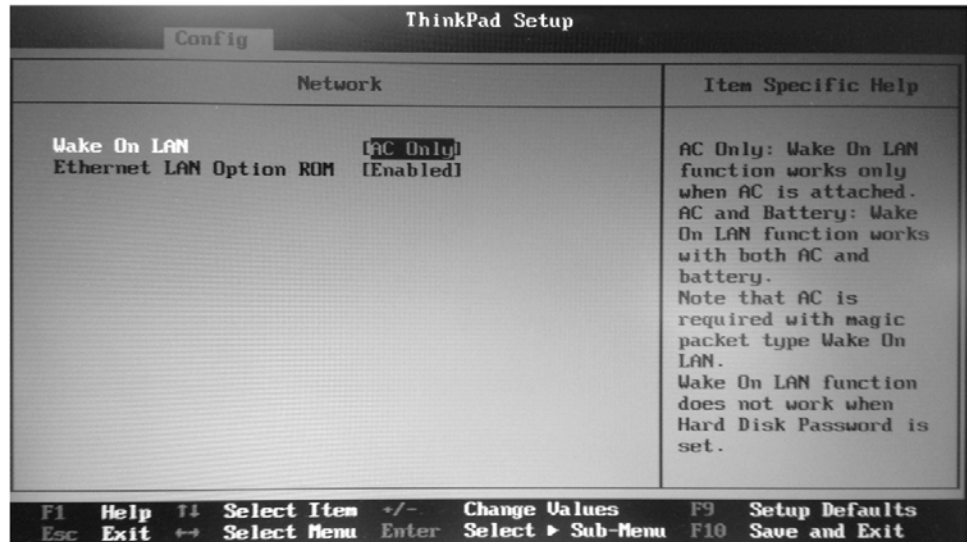

063D

5. Save BIOS changes and boot the computer into Windows.
6. Press the SYNC button to acquire the computer's MAC address.
7. The standby button's light will flash rapidly. Once the MAC address is acquired, the light will go solid for 3 seconds, off for ½ second and then stay on due to the computer's current draw.
8. If the Keypad Controller was not able to acquire the MAC address, the standby button's light will flash rapidly for several seconds and then it will go off or 3 seconds, on for ½ second and then stay on due to the computer's current draw. If the sync fails, most likely the Ethernet cable is not plugged into the computer and/or the Keypad Controller.
9. Open the Windows Device Manager.
 - a. Under Network Adapters, select the Ethernet connection (Typically it is an Intel Gigabit Network Connection).
 - b. Right click and select *Properties*.
 - c. Click on the *Power Management* tab.

d. Check *Allow this device to wake the computer*.

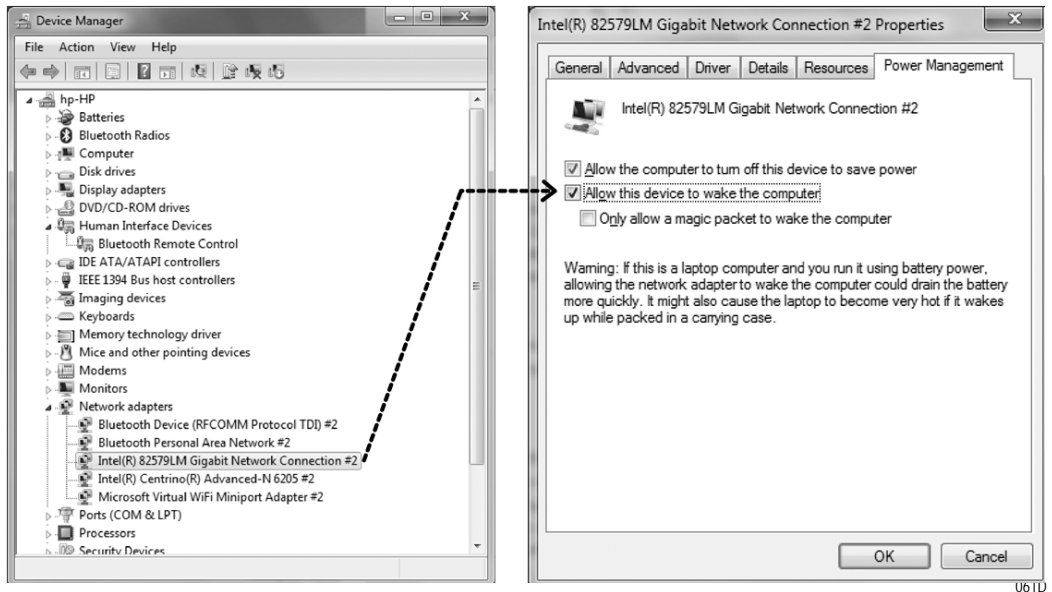

10. Shut down the computer using the Windows shutdown feature.

11. Turn on the computer via the keypad's standby button.

Wake on Power

Functioning

As soon as power is applied to the computer, the computer will boot up.

If the AccessPoint workstation is set up for Wake on Power (DC power cable plugged into the Wake on Power connector), DC power is applied to the computer after pressing the standby switch.

Wake on Power Setup

Plug Computer power cable into Wake on Power plug by referring to layout below.

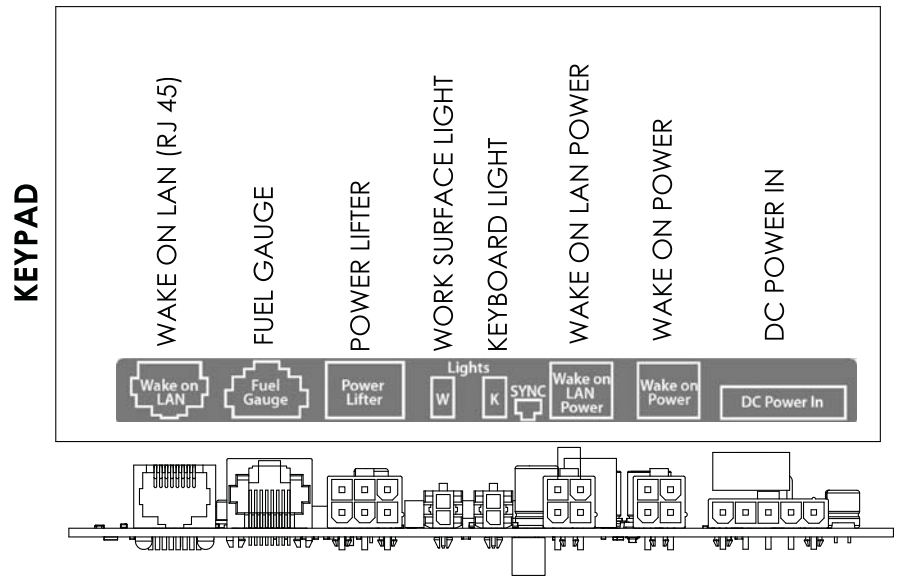

034D

Setup for Dell Laptop Computer

1. Connect power tip MT23 (marked "23") to computer power cable and plug in computer.

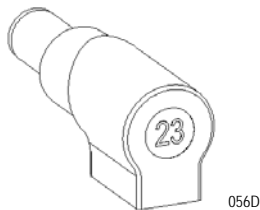

2. Press the standby button on the keypad/touchpad and immediately turn on the laptop computer by pressing its own standby switch.
3. As soon as the Dell Splash screen appears, press *F2* to access the laptop's BIOS.

4. Select *Power Management* and *AC Behavior*. Check *Wake on AC* as shown below.

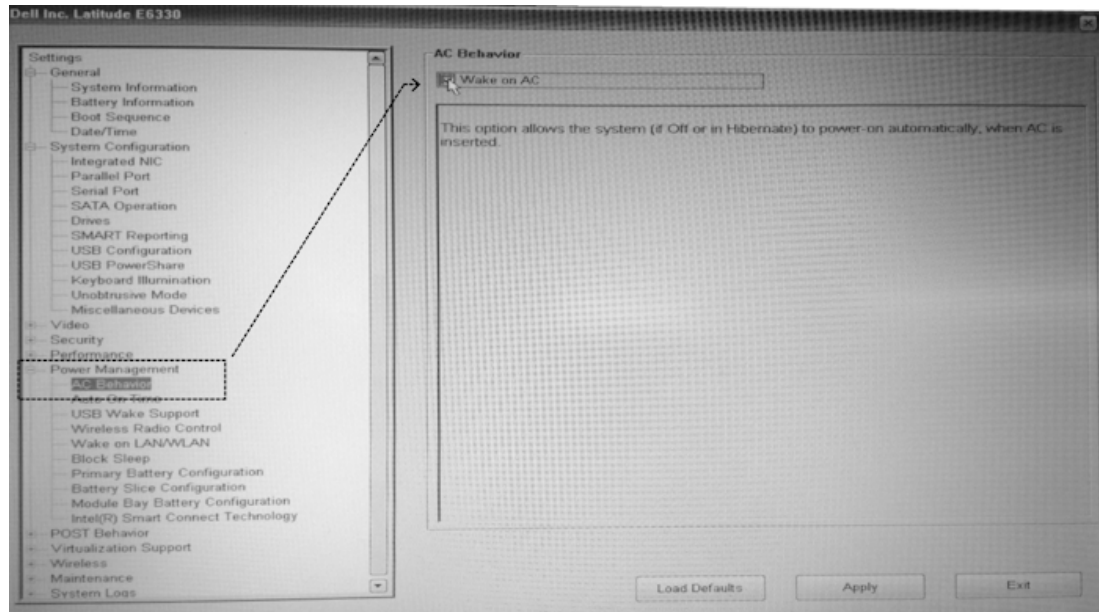

5. Save BIOS changes and boot the computer into Windows.
6. Shut down the computer using the Windows shutdown feature.
7. Turn on the computer via the keypad's standby button.

Setup for HP Laptop Computer

1. Connect power tip MT55 (marked "55") to computer power cable and plug in computer.

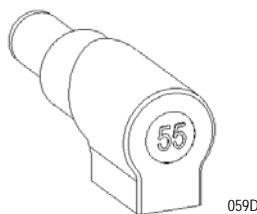

2. Press the standby button on the keypad/touchpad and immediately turn on the laptop computer by pressing its own standby switch.
3. As soon as the HP Splash screen appears, press *F10* or *ESC* to access the laptop's BIOS.

4. Select *System Configuration > Device Configurations*. Check *Power on unit when AC is detected* as shown below.

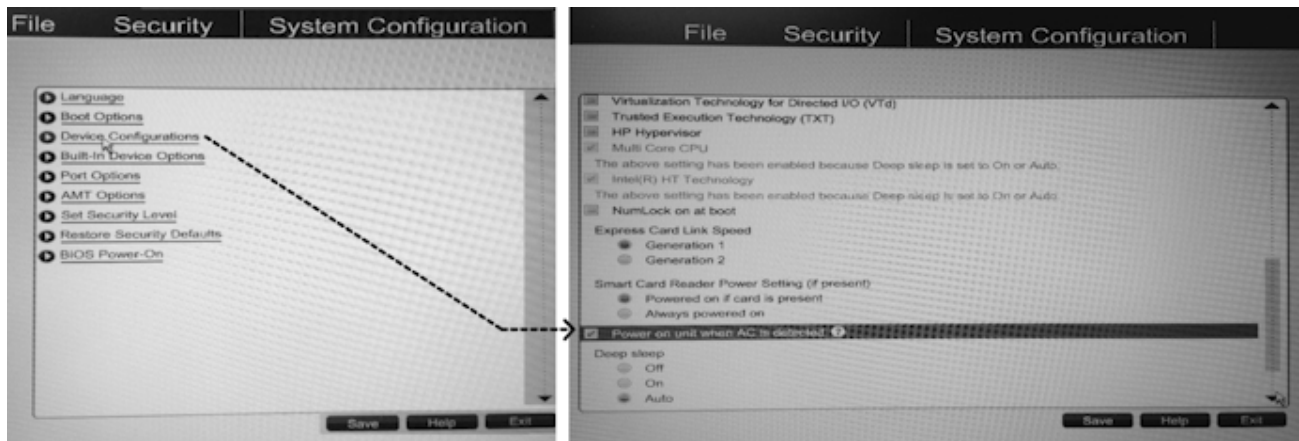

065D

5. Save BIOS changes and boot the computer into Windows.
6. Shut down the computer using the Windows shutdown feature.
7. Turn on the computer via the keypad's standby button.

Setup for Lenovo Laptop Computer

1. Connect power tip MT44 (marked "44") to computer power cable and plug in computer.

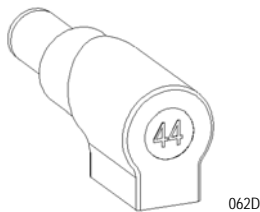

062D

2. Press the standby button on the keypad/touchpad and immediately turn on the laptop computer by pressing its own standby switch.
3. As soon as the Lenovo Splash screen appears, press *F1* to access the laptop's BIOS.
4. Select *Config > Power*. Enable *Power On with AC Attach*.
5. Save BIOS changes and boot the computer into Windows.
6. Shut down the computer using the Windows shutdown feature.

7. Turn on the computer via the Keypad/Touchpad's standby button.

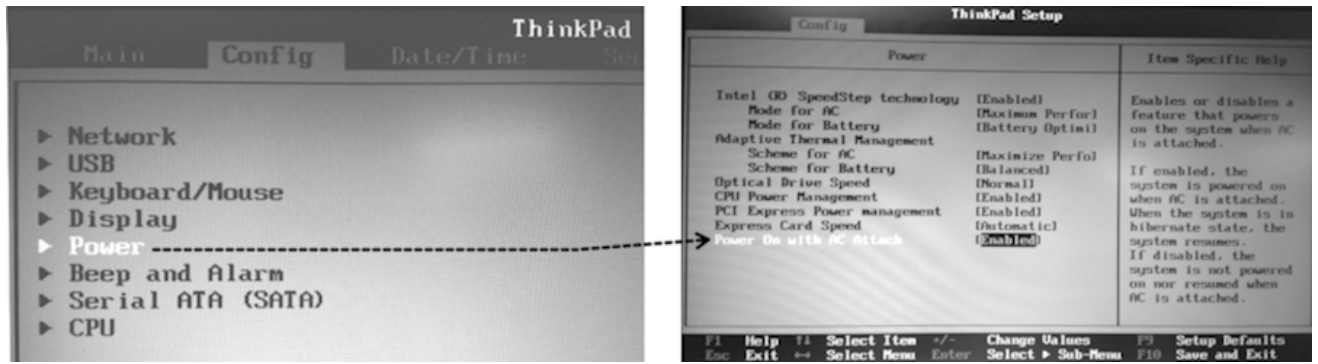

066D

3 Workstation Operation

Introduction	3-2
TouchPoint Medical AccessPoint Workstation Base	3-2
Power Supply	3-2
LED Lights	3-3
Keypad Controller	3-4
Keypad Controller LED Battery Fuel Gauge	3-5
Height Adjustable Column/Work Surface Adjustment	3-8
Raising the Workstation	3-8
Lowering the Workstation	3-8
Keyboard Tray	3-10
Monitor Mount	3-13
Rear Handle	3-14
Casters	3-15
Power Cord	3-15

Introduction

The TouchPoint Medical AccessPoint Mobile Computing System includes a Power Supply, Batteries (SLA, LiFe or Li-Nano), Power Cord, Expandable Technology Tray, Monitor Mount, Keypad Controller, Ergonomic Keyboard Tray, LED Lights, and a Height Adjustment Mechanism.

On selected AccessPoint workstation, you may see a Touchpad Controller, BatteryPro Software, Electronic Lifter, Dual Monitor, Ergonomic Push Handle, SecureRx Medication Module and/or APPOC LV Module.

TouchPoint Medical AccessPoint Workstation Base

The TouchPoint Medical Base is the backbone of every AccessPoint workstation. The Base features casters to wheel it around easily, provides mounting hardware to mount the power supply, and offers a foot rest to the user.

It supports gas assisted lifting mechanism or power actuator lifting mechanism for adjusting the height of the workstation in the range of 23-48" (584x1219 mm).

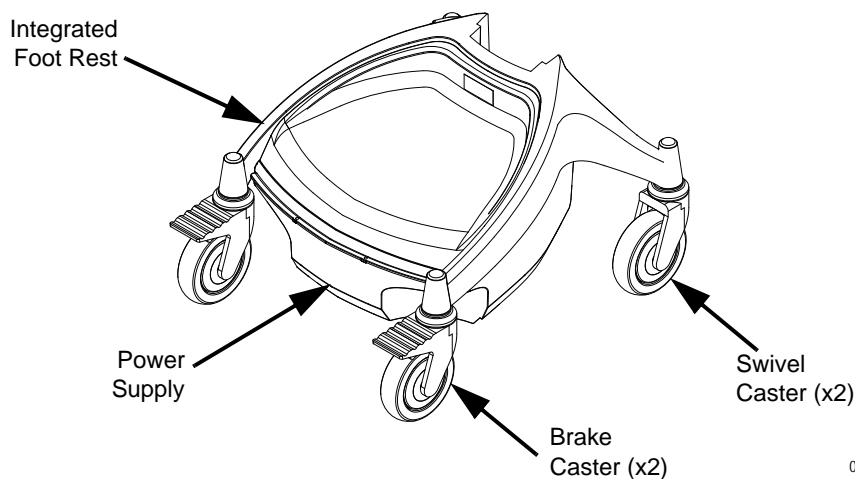

Power Supply

The Lithium Iron Nano-Phosphate (Li-Nano), Sealed Lead Acid (SLA) and LiFe are the rechargeable power sources for the AccessPoint workstations.

These power supply's are fully automatic power supply charger system with a nominal DC output voltage of 12 Volts (V) and a battery capacity of 512 to 540 Watt-hours (Wh) depending on chemistry.

When plugged into an AC outlet, it supplies power to the equipment while also charging the Li-Nano, SLA & LiFe cells.

When unplugged from the outlet, the power supply switches automatically to supply the equipment from the internal Li-Nano, SLA and LiFe rechargeable battery cells.

The power supply is designed for continuous operation and service is not interrupted by plugging in or unplugging the power supply.

NOTE

Anton Bauer is also a rechargeable power source for AccessPoint workstations. This power source is not used for dual monitor applications.

Power Up the Power Supply

The power supply is controlled by the “ON/OFF” switch located on the power supply that is typically mounted on the bottom of the AccessPoint workstation as shown in “[Charge Power Supply Battery](#)” on page 2-6. In the “ON” position the Power Supply provides power to the workstation and in “OFF” position power is removed from the workstation equipment.

NOTE

Li-Nano, SLA and LiFe are independent from charging electronics. Replacement consists of removal of batteries only. Contact customer service for information.

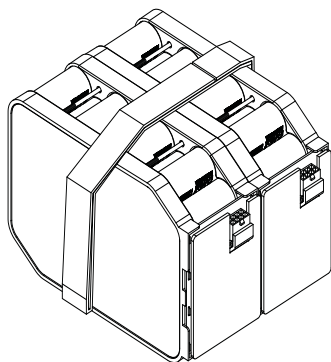

Li-Nano Battery

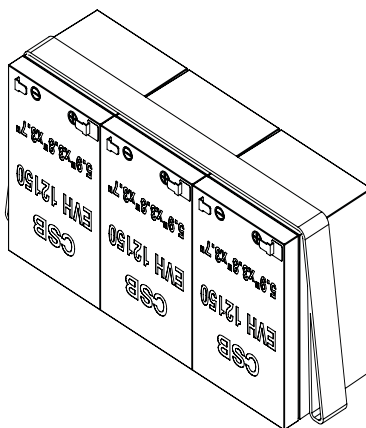

SLA Battery

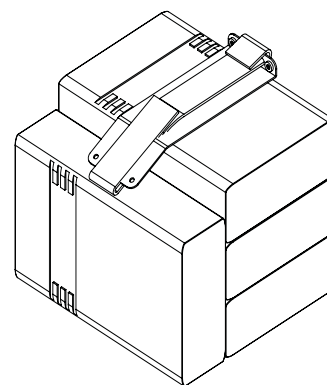

Li-Fe Battery

068D

LED Lights

For better visibility, white illuminating LEDs are located above the work surface and the keyboard tray.

The user can change the illumination of the work surface or the keyboard by operating the Keypad Controller. Moreover, there are five intensity settings,

by pressing the intensity control; the user has the ability to change level of intensity.

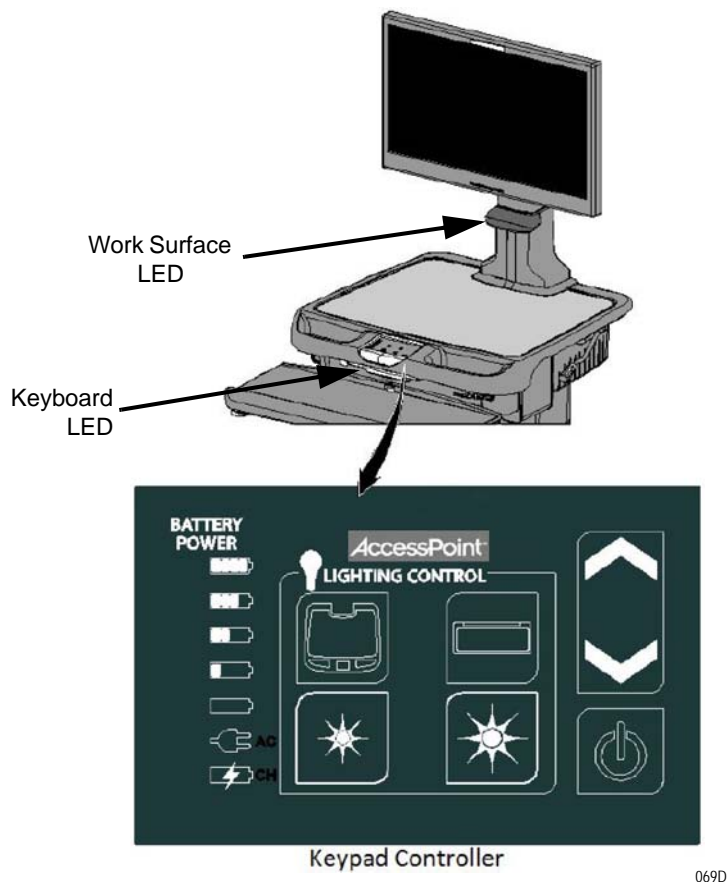

Keypad Controller

Keypad Controller is located on the front side of work surface.

By pressing the work surface or keyboard key you turn work surface or keyboard LED ON or OFF.

The standby switch in the lower right corner is used to turn on the computer equipment either by using “Wake on LAN” or “Wake on Power.” Holding the standby switch for more than 5 seconds will cut the power to the computer (this mode of shut down is not recommended).

The intensity of work surface or keyboard LED lights can be changed by pressing the “Star” button (HIGH/LOW) on the Keypad Controller.



The workstation height can be adjusted by pressing the Up or Down arrows on the Keypad Controller.

Keypad Controller LED Battery Fuel Gauge

The charge level of the battery cells when operating on DC power is indicated by “BATTERY POWER” LEDs.

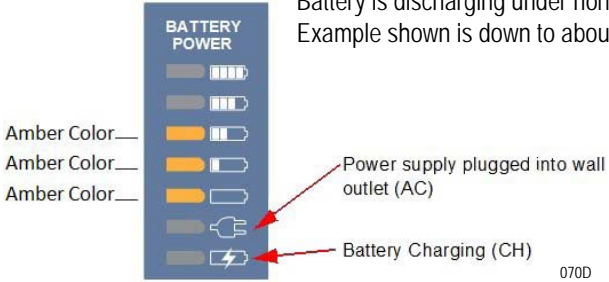
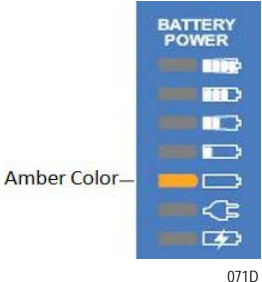
If the battery is fully charged, all five (5) amber LEDs are illuminated. The LEDs always display the battery charge level whether the computer is operating or not. As the battery loses charge, the LEDs gradually turn off, one at a time. Once the top four LEDs are off and only the bottom amber LED is illuminated and flashing, it is recommended to plug the AC cord into an AC outlet as soon as possible to charge the battery.

Fuel Gauge	Status
 <p>BATTERY POWER</p> <p>Amber Color—</p> <p>Amber Color—</p> <p>Amber Color—</p> <p>Power supply plugged into wall outlet (AC)</p> <p>Battery Charging (CH)</p> <p>070D</p>	<p>Battery is discharging under normal, mobile operation. Example shown is down to about 50% charge remaining.</p>
 <p>BATTERY POWER</p> <p>Amber Color—</p> <p>071D</p>	<p>Low battery LED flashing: plug power supply into AC immediately.</p>

Fuel Gauge	Status
 <p>072D</p>	<ul style="list-style-type: none"> ■ AC indicates the power supply is plugged into the wall AC. ■ CH indicates the battery is charging. ■ AC and CH LED must be ON. ■ The amber LEDs will turn on in sequence to indicate the charging status. ■ Example shown is up to about 50% charged.
 <p>073D</p>	<ul style="list-style-type: none"> ■ AC indicates the power supply is plugged into the wall AC. ■ The amber LEDs indicate the battery is fully charged. ■ Note that the CH LED is not lit because the battery is not being charged since the cycle is complete.

NOTICE

Once the power supply has been plugged into an AC outlet, the bottom two green LEDs will turn on.

Additional patterns with flashing LEDs indicate a problem with the power supply. See [“Power Supply and Battery”](#) on page A-3 for more information.

Charge Time

Charge time for fully depleted batteries depends on the amount of load connected to the power supply.

Typically it takes 2 hours in fan mode and 3 hours in fan less mode with LiFe and Li-Nano and 4 hours for SLA regardless of fan mode to fully charge a completely depleted battery, if the load of workstation electronics is less than 50 Watts. For a greater load, charging will take longer:

Examples:

Workstation electronics load is in a range greater than 120 Watts. The power supply can only provide less than 13A to charge 2 battery packs. The charge time will increase to over 3 hours.

Maximum charging current will resume once output load dropped.

Upon completion of the charge cycle, all 5 amber LEDs will be illuminated and the green CH (charge) LED will turn off, indicating that the batteries of the power supply are fully charged.

NOTICE

If the AccessPoint workstation is not used for an extended period of time, ensure the ON/OFF Switch is set to the OFF position. If the power supply is left in the ON position, the workstation equipment will continue to draw power and discharge the battery. Extended storage of empty batteries will cause permanent damage.

NOTICE

If the AccessPoint workstation is to be placed in long term storage (longer than one week), the power supply should be fully charged before placing the ON/OFF switch in the OFF position.

NOTICE

Power supply enters sleep mode after one week in extended storage. If the power supply has been switched to OFF for more than 1 week, connect the workstation to AC to wake up the power supply.

Height Adjustable Column/Work Surface Adjustment

The height adjustment release handle is used to adjust the height of the AccessPoint workstation.

The writing surface height can be set within a 20" dynamic range of adjustment, making it easier to type and read the monitor from either a standing or sitting position.

Raising the Workstation

1. Stand in front of the workstation and grasp the release handle with your right hand.
2. Grab the left side of the writing surface with your left hand.
3. Pull the release handle up.
4. While holding the release handle up, lift the writing surface to the desired height and then release the handle.

Lowering the Workstation

1. Stand in front of the workstation and grasp the release handle with your right hand. Grab the left side of the writing surface with your left hand.
2. Pull the release handle up.
3. While holding the release handle up, push the writing surface down to the desired height and then release handle.

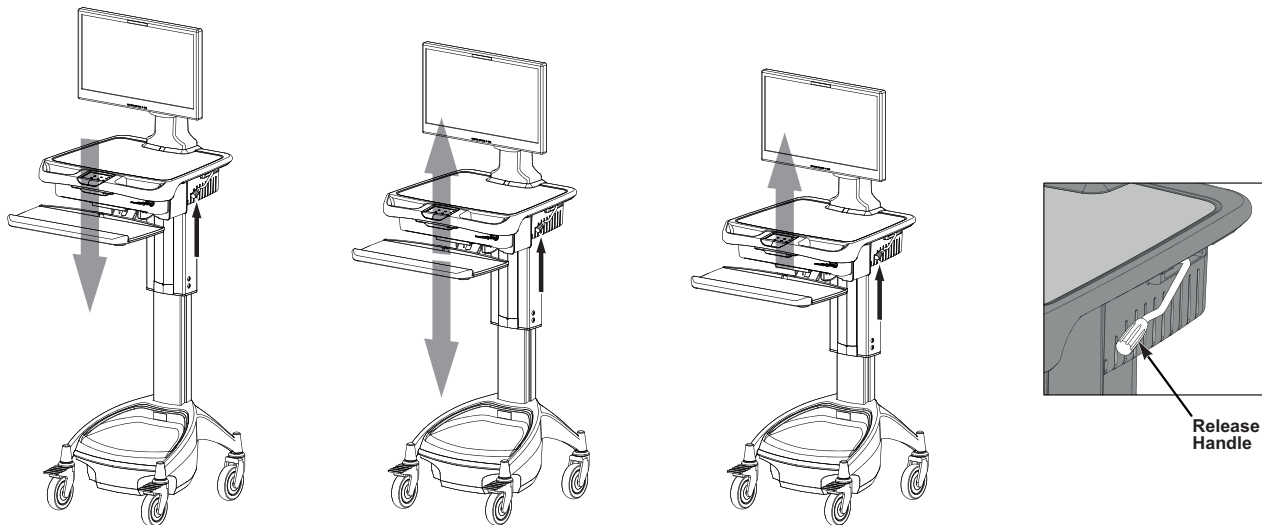

074D

Lowering the Workstation with Elifter

Access the keypad controller to adjust the height of the workstation when the cart is equipped with E-lifter.

1. Press and hold UP arrow to raise the work surface to the desired height. Release UP arrow to stop.

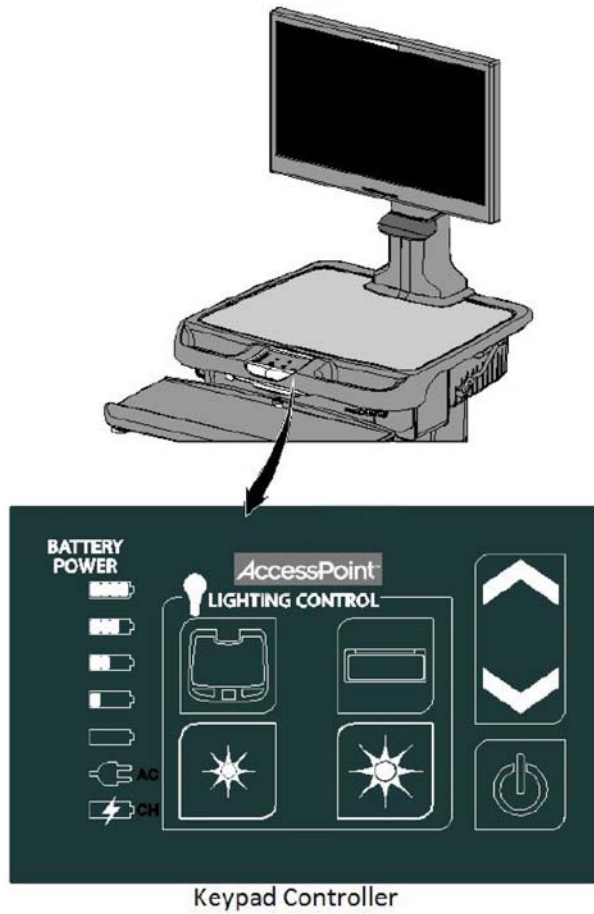

069D

2. Press and hold DOWN arrow to lower the work surface to desired height. Release DOWN arrow to stop.

Keyboard Tray

The keyboard tray can be adjusted for comfort and convenience; and is mounted under the technology tray. It can be moved in and out, up and down, left and right and can be tilted.

Rotating the small adjustment wheel in the clockwise direction gives 20° negative tilt of the keyboard tray with 10° interval.

Rotating the small adjustment wheel in the anti-clockwise direction gives 10° positive tilt of the keyboard tray as shown below.

A tilt indicator is located on the left side of the keyboard tray mechanism to identify the tilt angles.

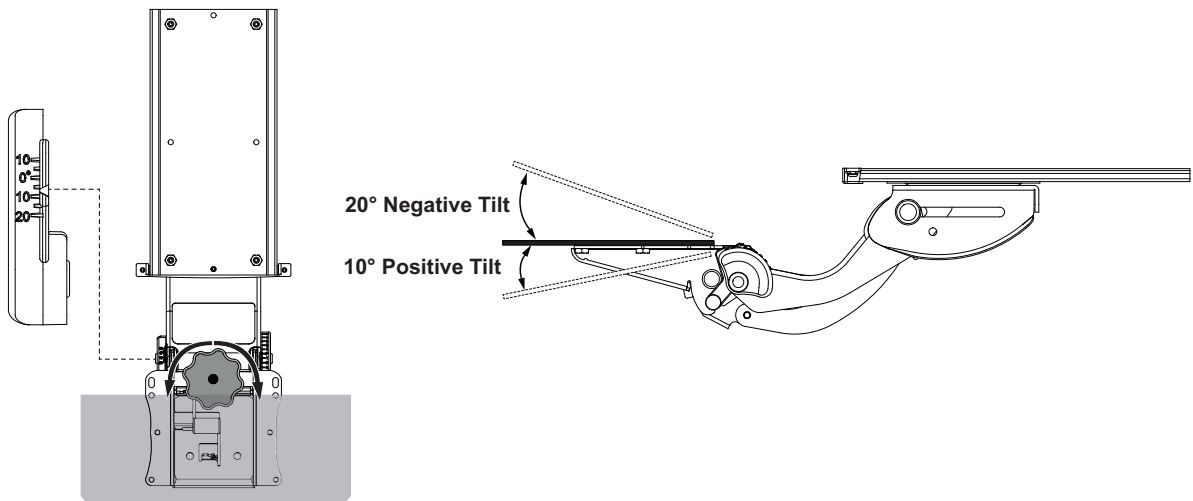

075D

To move the keyboard up, grasp with both hands and pull forward and lift up at the same time (3" height adjustment in upward direction).

To lower the keyboard or return it to the stowed position, lift up slightly on the front edge of the keyboard. This releases the locking mechanism and allows the keyboard to be lowered and glided back into its stowed position (5" height adjustment in downward direction).

On the right side of the keyboard tray mechanism a height indicator is located to identify the height intervals.

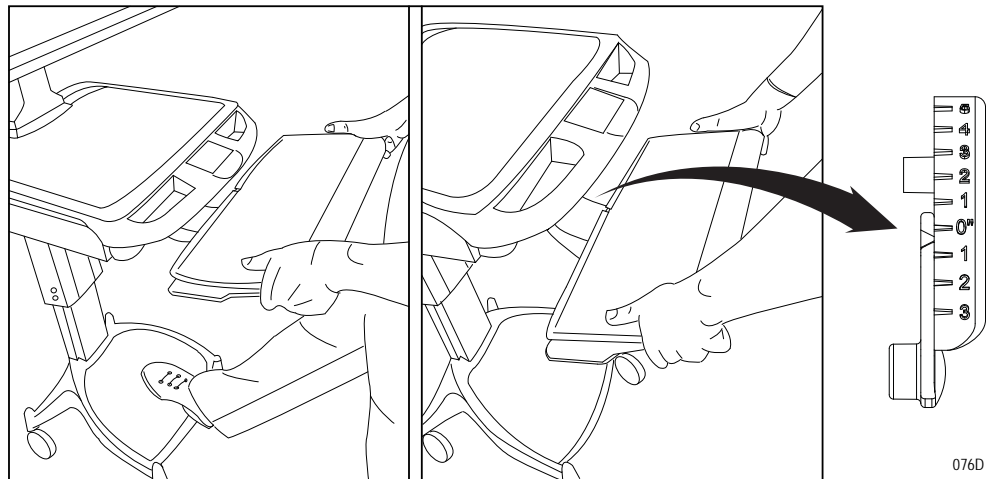

The entire keyboard tray can be rotated 90° towards left and right as shown below.

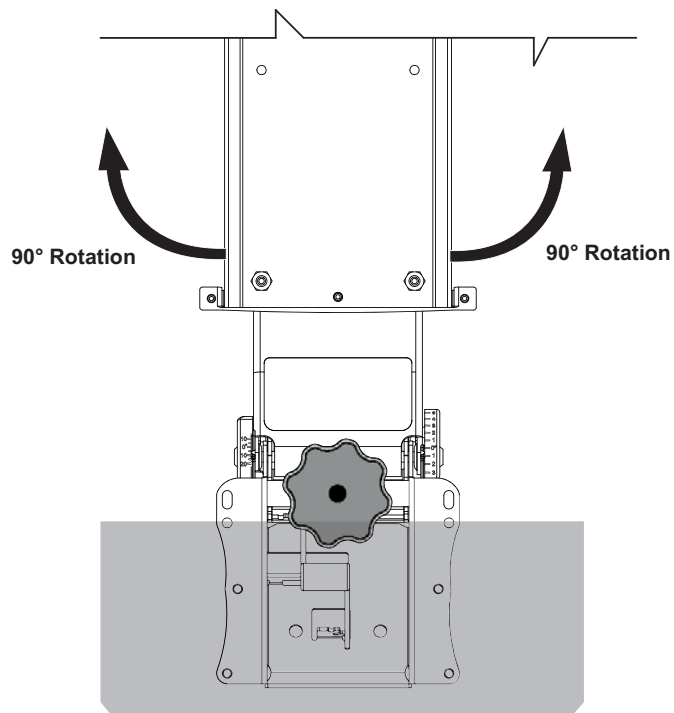

The AccessPoint workstation is also equipped with two flip out mouse pads. Simply pull and rotate the mouse pad out until the restriction in movement is felt.

NOTE

Before moving the workstation, center and stow the keyboard tray as well as retract the mouse pads.



078D



079D

Monitor Mount

The monitor mounting arm can be adjusted up or down and or simultaneously be tilted. This allows the user to place the monitor in a position for best viewing.

To adjust monitor position, grasp monitor with both hands and move to the desired position. Figure below shows highest and lowest positions of the monitor.

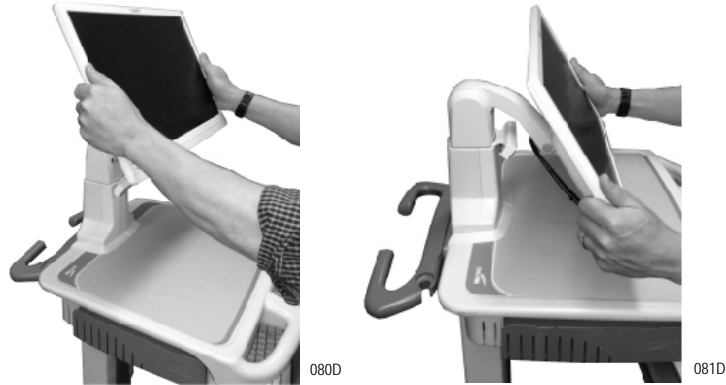

The monitor mount can be tilted 45° towards left and 45° towards right as shown below.

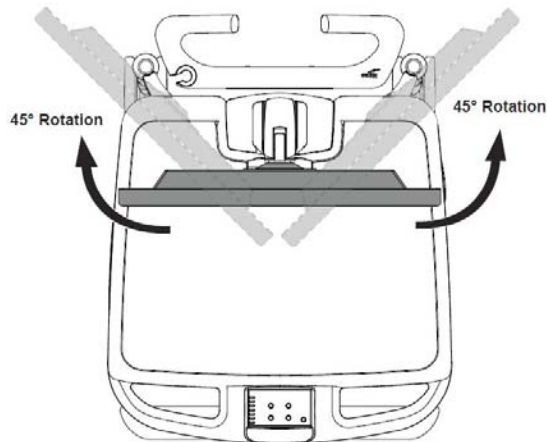

082A

To rotate the monitor face, grab the sides with each hand and move in a circle to the position desired.



Dual Monitor Mount

CAUTION



Do not install or operate APPOC LV module and 6-tier SecureRx module when there are dual monitors installed on the cart, otherwise tipping may occur.

Anton Bauer power source is not used for dual monitor applications.

Rear Handle

The AccessPoint workstation can be deployed with a rear handle designed to push the workstation by a nurse or doctor. Moreover, the user can attach the workstation power cord to the rear handle for easy transportation.

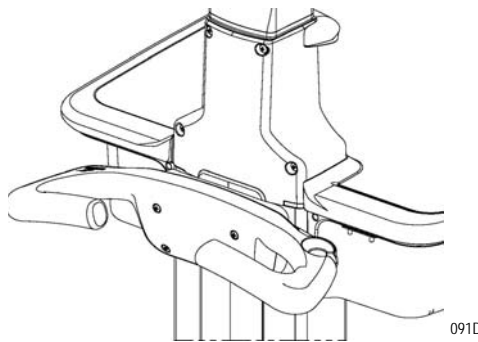

Casters

The AccessPoint workstation is configured with two locking and two non-locking casters. The two locking casters are on the front of the workstation.

To lock a caster in the front, press its locking tab down. To unlock a caster, lift its locking tab up.

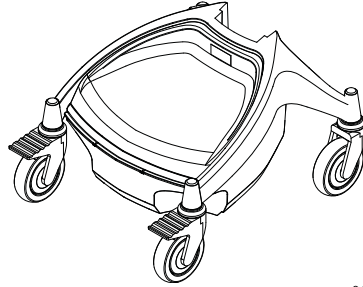

067D

Power Cord

Your mobile workstation comes with a coiled rubber cord. Its extended length is 8 ft and optionally, a 12 ft length is available as well. In the USA, the power cord is equipped with a hospital grade plug and shall be plugged into a hospital grade outlet only, to ensure grounding reliability. Outside the USA, your workstation comes equipped with your country's AC plug.

NOTICE

When unplugging the mobile workstation, grasp the cord at the plug and unplug. Do not unplug by pulling at the cable or pulling the entire workstation away from the outlet.

Power cord is available in following standards:

- Continental Europe
- UK
- Swiss
- Australian/New Zealand/China

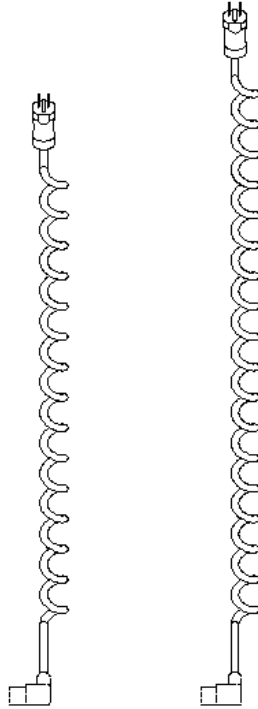
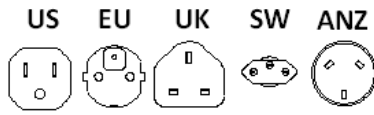

**8' AC Power
Cord**

**12' AC Power
Cord**

092D

4 Maintenance and Storage

Cleaning and Inspection	4-2
Disposal	4-3
Transport and Storage.....	4-3
Casters	4-3

Cleaning and Inspection

Use 70 percent isopropyl alcohol (IPA) diluted with water for cleaning the work station. You may also use one of these products:

- Cidex
- Clorox Clean-Up
- “Green soap” United States Pharmacopoeia (USP)
- Formula 409
- Sani-Cloth. Plus
- Virustat TBQ

NOTE

Do not use these products on the All-in-one computer or monitor. Do not wet electrical components or batteries when cleaning the workstation.

Ensure that power supply is off and unplugged. Apply 70 percent isopropyl alcohol to a clean nonabrasive cloth and then wipe. Cleaners applied directly to the power supply or tech tray enclosure could leak inside and cause damage. Be careful not to splash solvents on the workstation.

Periodic checks should be performed for tightness of fasteners and screws. Preferable cleaning and inspection of the workstation should coincide with typical biomedical inspection of medical equipment (e.g. leakage current and ground continuity test). A six (6) month interval for periodic inspection is suggested.

Disposal

NOTICE

For batteries recycling/disposal in the United States and Canada, contact Call2Recycle.



005D



NOTICE

For other countries, batteries must be recycled/disposed of in compliance with local regulations.

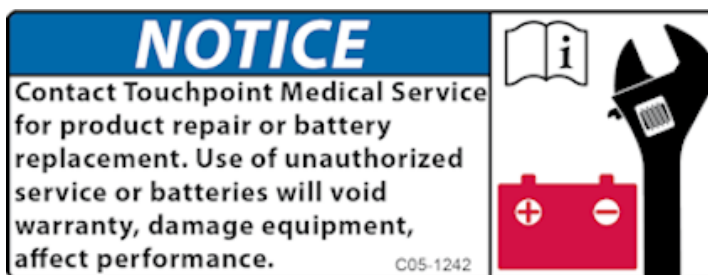

007D

Transport and Storage

During transport and storage the following conditions should not be exceeded:

- Temperature: -20 °C to 50 °C (-4 °F to 122 °F)
- Humidity: 5 - 90%, non condensing
- Altitude: 12,000 m (40,000 ft.)

Casters

Regularly inspect the casters. Tighten loose fasteners and replace worn or damaged parts with new TouchPoint Medical-approved parts. Replace worn or damaged casters immediately.

Page Intentionally Blank

Appendix A Troubleshooting

Overview	A-2
Power Supply and Battery	A-3
Low LED Flashing: Battery Nearing End of Charge	A-3
Power Supply Overheating	A-3
Battery Pack Overheating, Critical	A-4
Power Supply Low Temperature	A-4
No Battery Warning	A-5
Short Circuit or Overload	A-5
Power Supply Overheating, Charger Module	A-6
Low Battery Temperature Warning	A-6

Overview

Use the tips in this section as a guide. They include solutions to the simplest problems as well as things to observe when trying to diagnose problems.

Consider the following:

- If a problem occurs while you're working, stop immediately. If you continue, you may lose data and destroy problem-related information.
- Observe what is happening. Write down what the computer and any optional devices are doing as well as what actions you took immediately before the problem occurred.
- Is the computer running? Are the cables properly attached to the back of the Power Supply?
- Which part of the system is operating erratically? Keyboard? Display? Power Supply? Each produces different symptoms.
- What program and/or optional devices are you using?
- What appears on the screen? Do you see any messages or random characters? Look up any messages in the documentation for your software.
- Do you hear any beeps? How many? Are they long or short?
- Is the computer making any unusual noises?
- Are the brake casters locked or unlocked?
- Are the fuses in the Power Supply intact?
- See if you can cause the problem to occur again. This may help you understand the source of the problem and will help you describe the problem if you must call TouchPoint Medical Customer Service for technical assistance.

Power Supply and Battery

The power supply battery level flashes LEDs to indicate a detected problem. Warning LED indication legend:

Green or Amber Flashing LED:  093D

Grey LED off:  094D

Low LED Flashing: Battery Nearing End of Charge

Plug power supply into AC immediately.



Power Supply Overheating

AC/DC Module / DC1/DC2/DC3 Module

- Airflow in the power supply may be restricted due to cooling fan not working properly, fan blocked, temperature sensor may have failed or clogged ventilation slots around the power supply case.
- Turn off computer equipment and then the power supply.
- Check that the fan is not blocked. Check the ventilation slots around the power supply case for dust build-up and clean.
- Turn on the power supply and restart the computer.
- If this problem continues, contact TouchPoint Medical Customer Service.

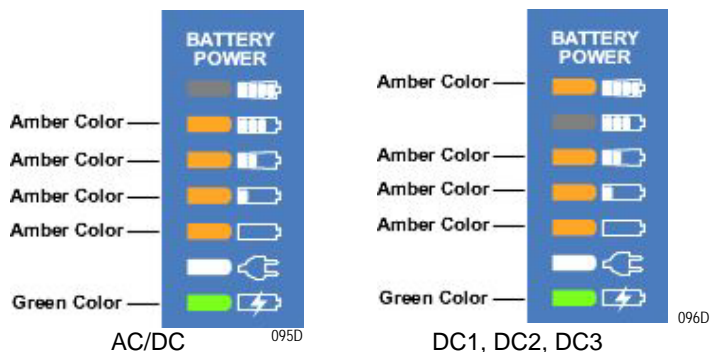

Battery Pack Overheating, Critical

- System will shut down in 2 minutes.
- Immediately turn off computer equipment and then the power supply.
- Let cool for 2 hours.
- Turn on the power supply and restart the computer equipment.
- If this problem continues, contact TouchPoint Medical Customer Service.

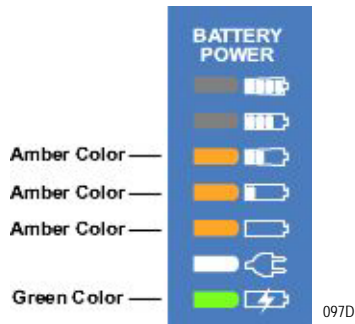

Power Supply Low Temperature

- System temperature below 0 °C (32 °F) has been detected. Ambient temperature is below operating range, temperature sensor has failed or has become disconnected.
- If power supply or its workstation are in an area where the temperature is below 0 °C (32 °F - freezing), move to an area of ambient temperature above 0 °C (32 °F - freezing), otherwise
- Turn off computer equipment and then the power supply.
- Turn on the power supply and restart the computer equipment.
- If this problem continues, contact TouchPoint Medical Customer Service.

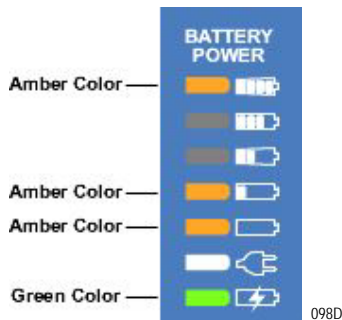

No Battery Warning

- No battery packs are detected in the power supply. Battery packs most likely are not connected before the power supply was placed into service.

NOTE

The battery cells may not be connected during shipment due to USDOT AND IATA regulations.

- Turn off computer equipment and then the power supply.
- Make sure battery packs are connected by performing procedure in Section “Connecting the Power Supply Batteries” above.
- Turn on the power supply and restart the computer equipment.
- If this problem continues, contact TouchPoint Medical Customer Service.

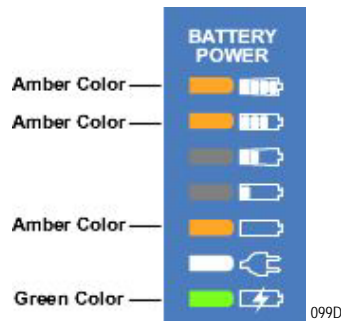

Short Circuit or Overload

- Power supply overloaded.
- Immediately turn off the power supply.
- Check your workstation for a possible short or overload.
- Turn on the power supply and restart the computer equipment.
- If this problem continues, contact TouchPoint Medical Customer Service.

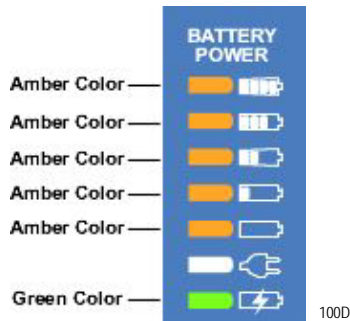

Power Supply Overheating, Charger Module

- Airflow in the power supply may be restricted due to cooling fan not working properly, fan blocked, clogged ventilation slots around the power supply case or failed temperature sensor.
- Turn off computer equipment and then the power supply.
- Check that the fan is not blocked. Check the ventilation slots around the power supply case for dust build-up and clean.
- Turn on the power supply and restart the computer equipment.
- If this problem continues, contact TouchPoint Medical Customer Service.

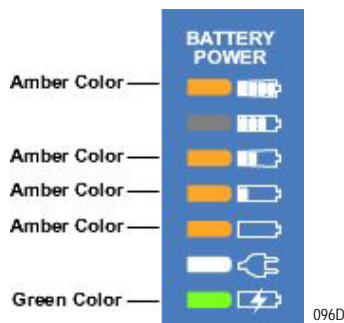

Low Battery Temperature Warning

Temperature sensor failure or batteries stored in low temperature environment.



Appendix B Accessories & Equipment Return

Accessories for AccessPoint Workstations.....	B-2
Anton Bauer External Power Replacement Kit	B-3
Equipment Return	B-4

Accessories for AccessPoint Workstations

Part Number	Description
Accessories	
AP-AL8RAIL	8" Accessory Rail
AP-AL14RAIL	14" Accessory Rail
AP-AL18RAIL	18" Accessory Rail
AP-ALUTILBASKET	Standard Utility Basket
AP-AL1GLOVEH	Glove Box Holder (1 Box)
AP-ALSSHARPSH	Standard Sharps Holder
AP-ALSWASTEH	Standard Waste Basket Holder
AP-AL9STORBASKET	9" Storage Basket
AP-ALSCHARTH	Standard Chart Holder
AP-AL10STORBASKET	10" Storage Basket
AP-AL2GLOVEH	Glove Box Holder (2 Boxes)
AP-AL3CHOSEORG	3 Clip Hose Organizer
AP-AL6CHOSEORG	6 Clip Hose Organizer
AP-AL1UTILHOOK	Single Utility Hook
AP-ALSPOLEH	Standard Pole Holder
AP-ALREARHANDLE	Polymer Rear Handle w/Mounting Bracket
APLV-LSRAIL14	AccessPoint LV Accessory Rail 14"
APLV-LARAIL	AccessPoint LV Accessory Rail 17" L with Clips
APLV-DD5	AccessPoint LV Patient Drawer Dividers 5"
APLV-DD7	AccessPoint LV Dividers 7-1/2" Wide Clear
APLV-DD11	AccessPoint LV Dividers 11-1/4" Long Clear
APLV-CCLIP	AccessPoint LV Cassette Quick Clips (pack of 40)
APLV-AWBIN	AccessPoint LV Wire Storage Bin Accessory
APLV-AWASTE	AccessPoint LV Waste Bin Accessory

Part Number	Description
Storage	
AP-AFNLSDCABINET	Single Drawer, Non Locking Cabinet Kit
AP-AFSOSDCABINET	Single Drawer, Southco Locking Cabinet Kit
AP-AFSUSDCABINET	Single Drawer, Supra Locking Cabinet Kit
AP-AFELSDCABINET	Single Drawer, Southco Electric Locking Cabinet Kit (32 Bit Operating System Only)
AP-AFKPSCABINET	Single Drawer, Southco Electric Keypad Locking Cabinet Kit
AP-AFNLDDCABINET	Double Drawer, Non Locking Cabinet Kit
AP-AFSODDCABINET	Double Drawer, Southco Locking Cabinet Kit
AP-AFSUDDCABINET	Double Drawer, Supra Locking Cabinet Kit
AP-AFELDDCABINET	Double Drawer, Southco Electronic Locking Cabinet (32 Bit Operating System Only)
AP-AFKPDDCABINET	Double Drawer, Southco Electronic Keypad Cabinet Kit
AP-AFNLTDCABINET	Triple Drawer, Non Locking Cabinet Kit
AP-AFSOTDCABINET	Triple Drawer, Southco Locking Cabinet Kit
AP-AFELTDCABINET	Triple Drawer, Southco Electronic Locking Cabinet Kit (32 Bit Operating System Only)
AP-AFKPTDCABINET	Triple Drawer, Southco Electronic Keypad Locking Cabinet Kit
AP-AFSOMKCABINET	2 Drawer Southco McKesson Cabinet Kit
AP-AFELMKCABINET	Southco Electronic McKesson Cabinet (32 Bit Operating System Only) Kit
AP-AFKPMKCABINET	Double Drawer, Southco Electronic Keypad Locking Cabinet Kit

Anton Bauer External Power Replacement Kit

Part Number	Description
RPEA-BANANAPIN	Replacement Gold Plated Banana Pin
RPEA-BATTERY-240	Replacement Elora Swappable Battery 240W Qty 1
RPEA-BATTERYINT	Replacement Elora Battery Interface AC Output
RPEA-FUELGAUGE	Replacement Elora Fuel Gauge
RPEA-POWERSUPPLYCART	Replacement Elora Power Supply for Cart
RPEA-POWERCORD	Replacement Elora Power Cord

WARNING

Remove batteries if equipment is not likely to be used for some time.

NOTE

See “Reference Documents” on page 1-12 for manuals providing detailed information on Anton Bauer.

Equipment Return

Should you need to return the equipment, complete the following steps to ensure proper acknowledgment/credit and to ensure the equipment is returned to the correct facility.

1. Obtain the serial number from the label, located on the back of the workstation and on tech tray near height adjustment handle.

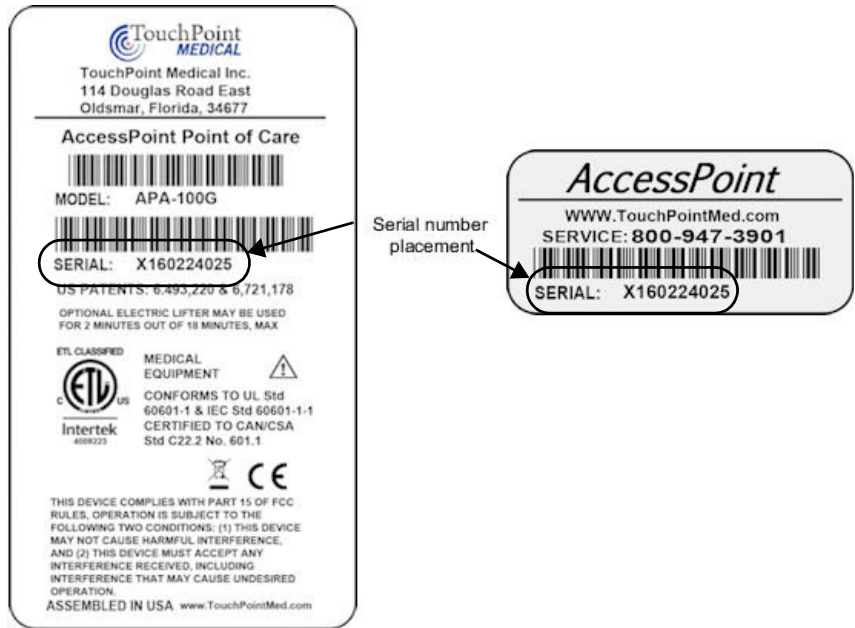

102A

2. Contact TouchPoint Medical Customer Service to obtain an RMA (return material authorization) number.

1-800-947-3901	Americas
877-671-3162	International
800-852-627	Australia
855-894-2710	Mexico

NOTE

Be sure to write the RMA number on the air bill in the reference section and the outside of the package.

Appendix C Technical Specifications

[Technical Specifications TouchPoint Medical AccessPoint Workstation . . C-2](#)

Technical Specifications TouchPoint Medical AccessPoint Workstation

Work Surface Height Range	23" - 48" (584 X 1219 mm)
Work Surface	267 sq in (19.3" L x 15.4" W) (172, 258 sq mm)
Maximum Work Surface Load	5 lbs
Weight	120 lbs with Laptop and Monitor 110 lbs without Computer 166 lbs with 4-Tier SecureRx Med Module
Overall Height	72" (178 mm)
Base Dimensions	16.75" x 17.5" (425 X 445 mm)
Construction	Aluminum Base, Aluminum Column and Work Surface with Aluminum Support Structure
Finish	Industrial Powder Coat
Casters	Four Swivel: Two Locking, Two Non-Locking (Low Rolling Resistance on All Surfaces)
Input Voltage	100 - 240 VAC @ 4.5 amps, max
Output Voltage	10.5-16 V Unregulated 12-24 V Selectable 5-10 V Selectable
Battery Technology	Lithium Iron Nanophosphate (Li-Nano) Lithium Iron Phosphate (LiFe) Sealed Lead Acid (SLA)
Operating Temperature	10 °C to 30 °C (50 °F to 86 °F)
Computer	Laptop computers up to a screen size of 17". Various thin clients and ultra slim desktops. All-in-one computers with a weight of up to 20 lbs. If capable, computers can be turned on via Wake on LAN or Wake on Power from the workstations keypad.
Communication	Wireless LAN connectivity provided by laptop computer, thin client or ultra slim desktop. An antenna external to the computer with MMCX or RP-SMA connector available.
Monitor	22", 24" LED Monitors 22" LED Monitor with Touchscreen Dual Monitors
Approvals	FCC Part 15 Subpart B, Class A, Industry Canada Class A UL60601-1 and CSA C22.2 No 601.1, 2nd Edition IEC/EN 60601-1-1 (Safety, Medical Equipment), 2nd Edition IEC/EN 60601-1-2 (EMC, Medical Equipment) RoHS compliant (RoHS Directive 2002/95/EC)

Appendix D Warranty Information

TouchPoint Medical AccessPoint™ Standard Limited Warranty	D-2
Resolution Procedure	D-2
Replacement Parts and RMA Policy	D-2
What is Covered	D-3
Warranty Exclusions—What is Not Covered	D-3

TouchPoint Medical AccessPoint™ Standard Limited Warranty

TouchPoint Medical warrants its AccessPoint mobile computing workstations (hereinafter, “Product”) to be free from defects in material and workmanship for a 5-year period on durable mechanical components and for a 2-year period on electrical components from Product ship date. Batteries are not considered mechanical or electrical parts and are covered under a separate warranty. All refurbished power supplies purchased from TouchPoint Medical will be covered for a one (1) year period from date of shipment; any other refurbished equipment purchased directly from TouchPoint Medical will be covered for ninety (90) days from the date of shipment.

Resolution Procedure

If within thirty (30) days after Customer’s discovery of any warranty defects within the warranty period, Customer shall promptly notify TouchPoint Medical in writing of the nature of the defect, or shall notify TouchPoint Medical of the nature of the defect through TouchPoint Medical’s Customer Service offices via telephone at 1-800-947-3901 or as specified at www.touchpointmed.com. Failure by Customer to give such written notice within the applicable time period shall be deemed an absolute and unconditional waiver of Customer’s claim for such defects.

If TouchPoint Medical determines that the Product is covered under this standard warranty then it is within TouchPoint Medical’s sole discretion to determine how to best address a customer’s warranty issues. If TouchPoint Medical can determine a solution, any necessary parts will be shipped to the Customer at TouchPoint Medical’s expense and a Return Merchandise Authorization (“RMA”) may be issued, if necessary. If TouchPoint Medical cannot find a solution to the Customer’s issue, then the call will be escalated through a tiered process to include Engineering assistance. If at any time during the warranty period, a customer submits a warranty claim where the Product is later found not to be defective, any on-site service calls and/or replacement Product will be charged to the customer at TouchPoint Medical’s then-prevailing prices/rates.

Replacement Parts and RMA Policy

If TouchPoint Medical issues a RMA to the Customer then all parts specified on the RMA must be returned to TouchPoint Medical with shipping expense to be paid by TouchPoint Medical. Any parts not returned to TouchPoint Medical will be paid for, in full, by the customer. Collect shipments will not be accepted. TouchPoint Medical shall be deemed the owner of all removed and repaired TouchPoint Medical furnished parts from the Product. Product repaired or replaced during the warranty period shall be covered by the foregoing warranty for the remainder of the warranty period or ninety (90) days, whichever is longer.

What is Covered

Mechanical components covered under this standard warranty include gas spring lifter, monitor mount(s), keyboard tray, casters, drawer slides, key locks, drawers and medication bins. Electrical items covered under this warranty include lifting and/or locking mechanisms, computers, monitor(s), power supply, power cords and cables, fuses, servo motors, USB hub, radio card, inverter, power brick, electronic touch pad, and peripherals such as mouse and keyboard. Only components furnished and installed by TouchPoint Medical onto the Product will be covered under this warranty.

Warranty Exclusions—What is Not Covered

This Limited Warranty does not cover consumables, including batteries (which are covered under a separate warranty), customer furnished equipment, vital signs monitors, damage or operational malfunction of the Product caused by accident, misuse, neglect, failure to follow proper use instructions, unauthorized repair attempts, or by the integration or addition of peripheral components or Product modifications of parts without TouchPoint Medical's prior written consent. This Limited Warranty does not cover damages or defects due to or caused by abuse, loss, negligence, accident, physical damage, and/or misuse, an Act of God, or unauthorized service or repair of the Product, damage from electrical power problems, usage of parts or components not supplied by TouchPoint Medical, failure to follow product instructions and guidelines, unauthorized changes or alterations to the Product, shipping damage (other than during original shipment from TouchPoint Medical), failure to perform preventive maintenance, or damage caused by peripherals or software or from other external causes not the fault of TouchPoint Medical.

This limited warranty is extended only to the original end user, is non-transferable and terminates if the original purchaser transfers the Product to another person or entity. For this warranty to be valid, the Product must have been purchased directly from TouchPoint Medical or from an authorized representative of TouchPoint Medical. Proof of original ownership may be required.

THE SOLE AND EXCLUSIVE REMEDY FOR ANY BREACH OF THIS LIMITED WARRANTY SHALL BE LIMITED TO REPAIR OR REPLACEMENT OF THE PRODUCT, OR REFUND OF THE ORIGINAL PURCHASE PRICE FOR THE PRODUCT. The limit of the liability of TouchPoint Medical to repair the Product after a reasonable amount of time and a reasonable number of attempts shall be the replacement of the Product or a refund of the original purchase price of the Product. The decision regarding repair or replacement of the Product or refund of the original purchase price shall be at the sole discretion of TouchPoint Medical.

Page Intentionally Blank

Index

-
- A**
- AC Inverter 2-15
 - Accessories B-1
 - Adjustable Column 3-8
- B**
- Battery
 - Charge 2-6
 - Connect 2-3
 - Disposal 1-5, 4-3
 - Recharge 1-8
 - Recycle 1-5, 4-3
 - Battery Fuel Gauge 3-5
 - Charge 3-6
- C**
- Cable Connections 2-8
 - Cables
 - Set up 2-21
 - Canada Industry 1-10
 - Casters 1-2
 - Chapter Content 1-6
 - Computer Power Tips 2-8
- D**
- Damage 1-8, 1-9
- E**
- Equipment Return B-4
- F**
- FCC 1-9
 - foot 3-2
 - Footrest 1-2
- H**
- Height Adjustment 1-2
- I**
- Illustrations 1-6
 - Integration 2-8
 - Mouse 2-22
 - Technology Tray 2-13
 - Work Surface 2-12, 2-24
 - Intertek Certification 1-4, 1-8
 - Void 1-5
- K**
- Keyboard Tray 1-2
 - Keypad Controller 1-2, 3-4
 - LED Battery Fuel 3-5
- L**
- LAN 2-25
 - LED 3-3
 - LiFe Battery 2-2
 - Li-Nano Battery 2-3
 - Class 9 2-3
 - Non Class 9 2-3
 - Load
 - Computer Equipment 1-5
 - Monitor 1-5
 - Load Limit 1-9
- M**
- Maintenance 4-1
 - Casters 4-3
 - Cleaning 4-2
 - Inspection 4-2
 - Monitor Counter-Balance Adjustment 2-19
 - User 1-8
 - Manual Conventions 1-7
 - Monitor 1-5, 3-13
 - Mount 3-13
 - Mounting Arm 3-13
 - Monitor Counter-Balance Adjustment 2-19
 - Monitor Knuckle 2-18
 - Monitor Mount 1-2
 - Multiple Portable Socket Outlet 1-5
- O**
- Options
 - BatteryPro Software 1-2
 - Dual Monitors 1-2
 - Electronic Lifter 1-2
 - Ergonomic Push Handles 1-2
 - SecureRx Medication Module 1-2
- P**
- Power Supply 1-2, 3-2
 - AC 1-5
 - AC circuit 1-4
 - Battery-only 1-2
 - Charging, Fan 1-2
 - Charging, Fan-less 1-2
 - DC 1-5
 - LiFe 1-9
 - Li-Nano 1-9
 - Peak 2-14
 - Power Up 3-3
 - Shipment 2-2
 - SLA 1-9
 - Total 2-14
 - Product Notice 1-4
 - Power Supply 1-4
- R**
- Regulatory Compliance 1-8
 - Revision History 1-11
 - RMA B-4
- S**
- Safety 1-8, 1-10
 - Safety Information 1-8

Cautions 1-8
Dangers 1-8
Warnings 1-8
SLA Battery 2-3
Specifications
 AC Inverter 2-15
Storage 4-1
 Transport 4-3

T

Technical Specifications C-1
Technology Tray 1-2, 2-13
 Set up Computer 2-15
TouchPoint Medical Address B-4
Troubleshooting A-1
 Battery A-3
 Battery Pack Overheating A-4
 Charger Module A-6
 Circuit Overload A-5
 Low Battery Temp A-6
 Low LED A-3
 No Battery A-5
 Power Supply A-3
 Power Supply Low Temp A-4
 Power Supply Overheating A-3
 Short Circuit A-5

U

USB 2-21
 AC Power 2-21
 DC Power 2-21

Set up 2-21

V

Voltage 2-10
 Configure 2-10

W

Wake on
 LAN 2-25
 Power 2-25
Warranty D-1
Weight
 Dual Monitors 1-5
Work Surface 1-2, 2-12
 Adjustment 3-8
Workstation 3-1
 Casters 3-15
 Inspect 2-2
 Keyboard Tray 3-10
 Lower 3-8
 Power Cord 3-15
 Raise 3-8
 Unpack 2-2
Workstation Base 3-2
 Casters 3-2
 Foot Rest 3-2
 Lifting
 Gas 3-2
 Power Actuator 3-2
 Power Supply 3-2

Page Intentionally Blank

This page intentionally blank.

www.touchpointmed.com

800.947.3901
info@touchpointmed.com



Bringing care forward.